

Evo system

Complete shower kit

Description

Shower system with integrated waterproofing, consisting of a low-profile trapped drain, a WATER-STOP waterproof membrane factory-bonded and sealed to a special adapter for direct connection to the drain, and a stainless steel grate with ABS cup.

Features

- Waterproofing included
- Offset drain position
- High drainage capacity
- Easy installation
- Removable hair strainer
- 10-year warranty

Technical data

- Elastic seals
- Secondary drainage
- 360° adjustable

Manufacturer

Estil Guru S.L.U

P.I. El Pla C/ Telers, 22 - Apdo. 584, 46870, Ontinyent,
Valencia, SPAIN | www.estilguru.com | guru@estilguru.com
Tel. 0034 96 291 45 11 | Fax. 0034 96 236 90 10

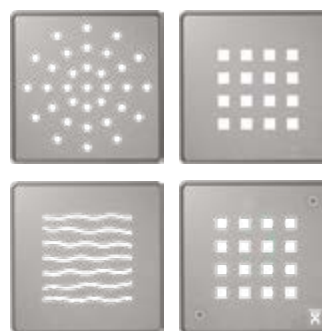

Product

Ruber H50	Ruber H28	Description	Finish	Flow rate (l/min)	W-S membrane
IB20015	IB20015R	Evo	●	24	1,5 x 2 · 3 m ²
IB20016	IB20016R	Plus Evo	●	26	1,5 x 2 · 3 m ²
IB20017	IB20017R	Onde Evo	●	26	1,5 x 2 · 3 m ²
IB20007	IB20007R	Disuasoria	●	26	1,5 x 2 · 3 m ²
IB20018	IB20018R	Plus Evo Polished	●	26	1,5 x 2 · 3 m ²
IB20019	IB20019R	Plus Evo Black	●	26	1,5 x 2 · 3 m ²
IB20020	IB20020R	Plus Evo Bronze	●	26	1,5 x 2 · 3 m ²
IB20021	IB20021R	Plus Evo Gold	●	26	1,5 x 2 · 3 m ²
IB20100	IB20100R	Evo	●	24	1 x 1 · 1 m ²
IB20101	IB20101R	Plus Evo	●	26	1 x 1 · 1 m ²
IB20102	IB20102R	Onde Evo	●	26	1 x 1 · 1 m ²
IB20104	IB20104R	Plus Evo Polished	●	26	1 x 1 · 1 m ²
IB20105	IB20105R	Plus Evo Black	●	26	1 x 1 · 1 m ²
IB20106	IB20106R	Plus Evo Bronze	●	26	1 x 1 · 1 m ²
IB20107	IB20107R	Plus Evo Gold	●	26	1 x 1 · 1 m ²

Evo system Complete shower kit

Test table

Features	Method	Requirement	Unit	Value
	EN 1253-1	EN 1253-1		
Drainage flow rate	Article 5.9.1	Article 4.8	l/s	>0,4
RUBER H50 water seal height (hydraulic seal)	Article 5.3.1	Article 4.2.2	mm	50
RUBER H28 water seal height (hydraulic seal)	Article 5.3.1	Article 4.2.2	mm	28
Pressure resistance of the water seal	Article 5.3.2	Article 4.1.6	Pa	>400
Self-cleaning capacity	Article 5.4.2	Article 4.2.2	-	Pass
Clogging prevention	Article 5.4.3	Article 4.2.3	-	Pass
Thermal behaviour	Article 5.5	Article 4.5	-	Class A
Watertightness	Article 5.8.2	Article 4.6.2	-	Pass
Watertightness of the extensions	Article 5.8.2	Article 4.6.3	-	Pass
Odour tightness	Article 5.8.1	Article 4.6.1	-	Pass
Watertightness of the drain when used with waterproofing membrane	Article 5.8.3	Article 4.7.3.4	-	Pass
Mechanical strength of the factory-mounted flange / waterproof membrane connection	Article 5.7.3	Article 4.7.3.4	N	>100
Load resistance	Article 5.6	Article 4.7.1	-	Class K3
Openings in the grates (dimensions)	Article 5.1	Article 4.1.3	mm	<8
Appearance	-	Article 4.1.2	-	Pass
Materials	-	Article 4.4	-	Pass

Features

- Allows the trap to be bypassed if there is an external trapped gully in the drainage network.
- Secondary drainage with a non-return system to remove infiltration water.
- Total installation height RUBER H50 (flush with grate), including floor finish + adhesive: minimum / maximum.
- Total installation height RUBER H28 (flush with grate), including floor finish + adhesive: minimum / maximum.
- Floor finish thickness when installed at minimum height: total thickness including installation adhesive.
- Maximum thickness of floor finish + tile adhesive.
- Push-fit connections between the different elements of the drainage system.
- Separation by elastic seals allowing slight movement between the parts.
- 360° adjustable horizontal outlet.
- Includes a protective cover for the drain opening during installation.

Warning: To avoid the risk of blockage caused by a double trap, before starting installation it is very important to check whether a trapped drain is required or whether it will be installed with an external trapped gully.

The system body is designed as a trapped drain, but the water seal can be bypassed. If necessary, follow the instructions in the installation procedure.

The trap cannot be bypassed after installation, nor can it be replaced. It is advisable to keep the trapped drain and connect it directly to the drain pipe without passing through the external trapped gully.

Evo system

Complete shower kit

Notes and observations

The nominal flow rate at 3 bar pressure for most shower heads is between 9 and 20 litres per minute. For shower drains, the minimum drainage flow rate required by the standard is 24 litres per minute for a single shower head. This minimum value does not apply to multi-jet showers or multiple-shower installations with a single drain.

For the values relating to the characteristics of the WATER-STOP membrane, refer to its technical data sheet.

The minimum installation height mentioned is the minimum possible due to the dimensions of the drain. In each installation, the actual effective minimum height will be the one that allows the drain pipe to be laid with the proper slope towards the drainage network, plus the thickness of the floor finish and its installation adhesive.

The drain pipe must have a minimum slope of 1.5% towards the drainage network. The length of this section should not exceed 1 m.

To move the drain: If the position of the drain point requires the drain to be moved, leaving excess membrane on one side and insufficient membrane on the other, the excess can be cut off while respecting the 10 cm upturn on walls, and bonded where needed by making the membrane joint with an overlap 5 to 10 cm wide and in the direction of the slope.

To bond overlap joints: In site-built showers and in small interior areas not subject to flooding, the same C2 tile adhesive used for the installation can be used. If maximum watertightness is required, make the joints using EASEAL polymer cement or a W-S MASTIC adhesive sealant.

To bond WATER-STOP to the substrate: On traditional building substrates, use C2 tile adhesive. For gypsum, existing ceramic tiling and others, check that the selected adhesive is suitable for the substrate. Apply following the manufacturer's instructions.

To bond finishes to WATER-STOP: For ceramic floor coverings or similar, use C2 tile adhesive. For wood, textile coverings and others, use an adhesive suitable for the finish and resistant to moisture. Apply following the manufacturer's instructions. You will find more detailed information in the ROOF INSTALLATION GUIDE.

To complete the waterproof protection: To create a shower free from damp caused by infiltration and condensation, it is not enough to install protection on the floor only. The walls must also be protected up to a height of 2 m. Use the WATER-STOP membrane and its accessories. If this is not possible, we recommend protecting at least the wall in the area of the water outlets and down to the floor.

The data shown are for information purposes only and may be modified without prior notice. Tests deemed appropriate must be carried out in order to verify the suitability of the product for the intended use when this differs from what is stated here.

Technical drawings

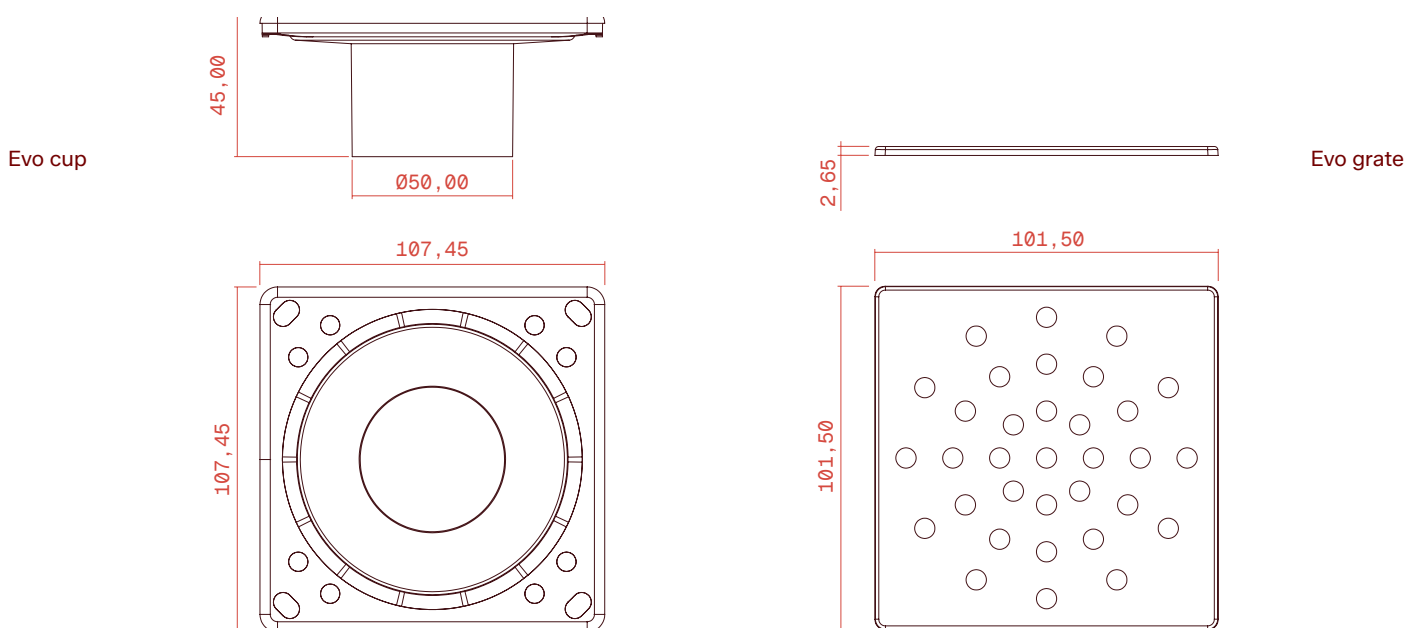

Technical drawings

Plus grate

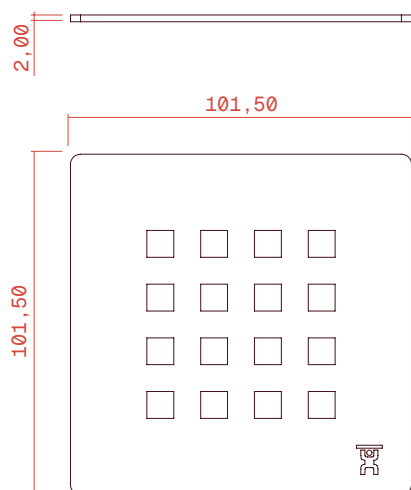

Tamper-resistant grate

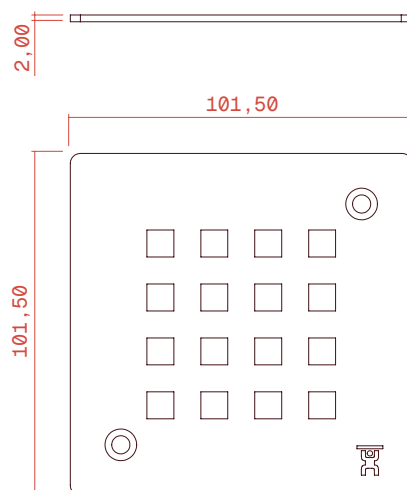

Components

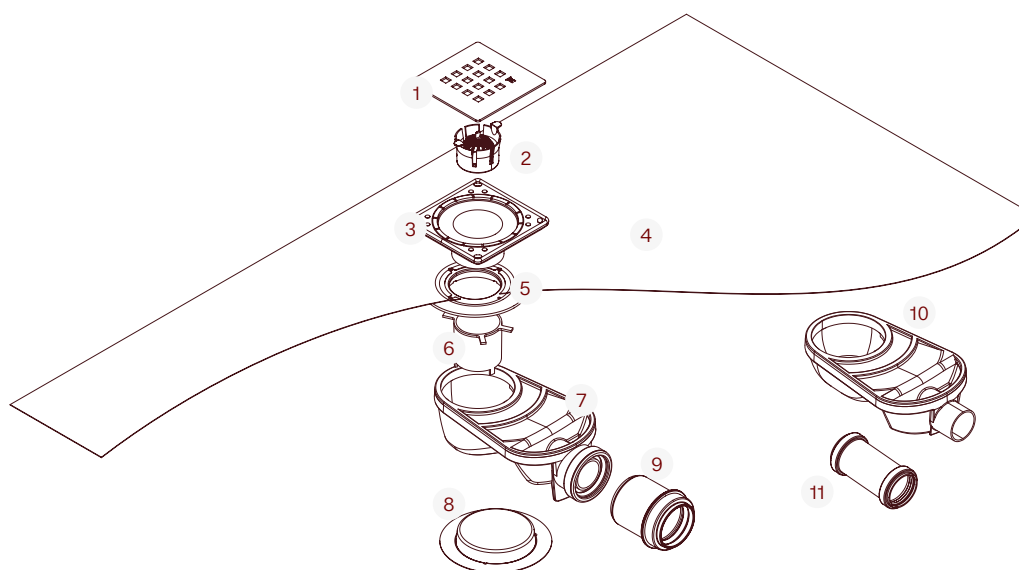

Part	Description	Material
1	Evo grate (depending on model)	Stainless steel
2	Hair strainer	ABS
3	Evo cup	ABS / Stainless steel
4	WATER-STOP membrane	EVAC
10	Adapter	ABS
11	Ruber collar	PP

Part	Description	Material
7	Ruber H50 drain	ABS
8	Protective cover	PP
9	Reducer *1	PVC
10	Ruber H28 drain *2	ABS
11	Ø40 sleeve *2	PP

*1 Included only with RUBER H50 | *2 Included only in reduced kits

Evo system Complete shower kit

Installation section

Ruber H50

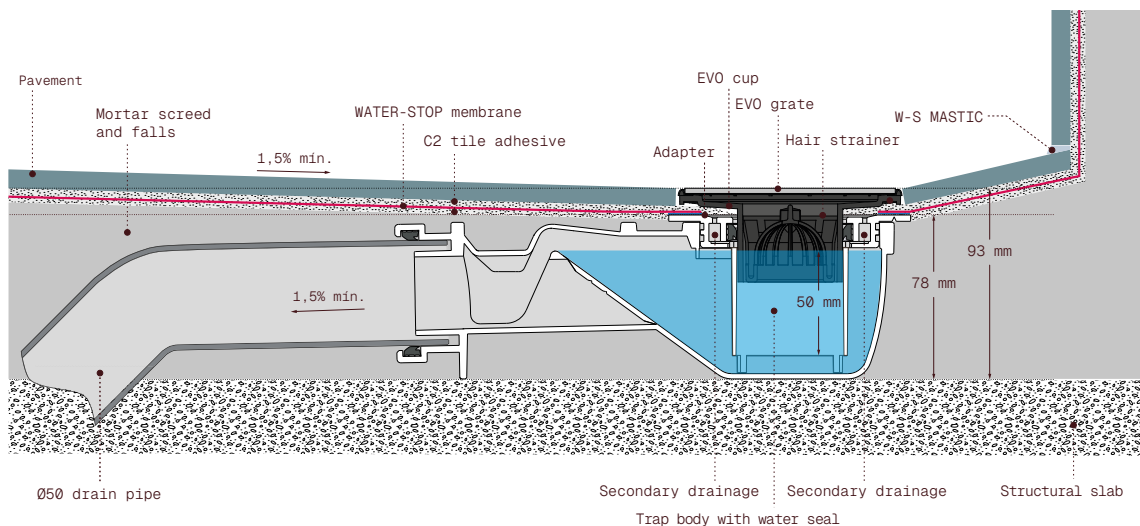

Ruber H28

