



GURU[®]
waterproofingproducts

Catalog 2026



Corporate Brochure

01 Corporate Brochure

02 Technical Membranes

03 Drainage Systems

04 Modular Systems

GURU is what we are and what we do.

On every page and at every stage, we build the essence of our identity. A solid track record that defines us, and a promising future that drives us forward.

GURU

One brand, one family.

25 years turning the technical into something human, and the invisible into a lasting experience.

We design solutions that protect from within.

With innovation as our tool and quality as our purpose, we are the largest membrane manufacturer in Europe. We are leading the waterproofing market into the future.



Our story, layer by layer



Our origin

Estil GURU is founded, bringing together the Gutiérrez and Ruiz families. The perfect balance between technical expertise and business vision..

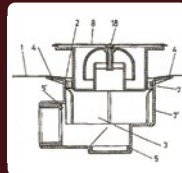

EVAC patent

We patented the first shower system with an EVAC membrane, reinforcing our commitment to innovation and the development of proprietary solutions.

2001 2002 2003 2004 2005 2006 2007 2008 2009 2010 2011 2012 2013



Launch of Water-Stop

We created our most iconic and distinctive waterproofing system, making installation easier for our customers..



New corporate phase

The Ruiz family acquires full ownership of the company. Under renewed leadership, we scale towards a more strategic vision.

Experience, innovation and growth

Industrial know-how and a passion for design have shaped our history.



International expansion

With the opening of subsidiaries in the USA and Italy, we drive the expansion of our know-how into key global markets.



New corporate headquarters

We inaugurated an additional 1,500 m², expanding our facilities to continue promoting maximum efficiency and innovation.

2014 2015 2016 2017 2018 2019 2020 2021 2022 2023 2024 2025 2026



GURU Headquarters

A new 20,000 m² production plant to strengthen our industrial capacity and market leadership..

GURU Methodology

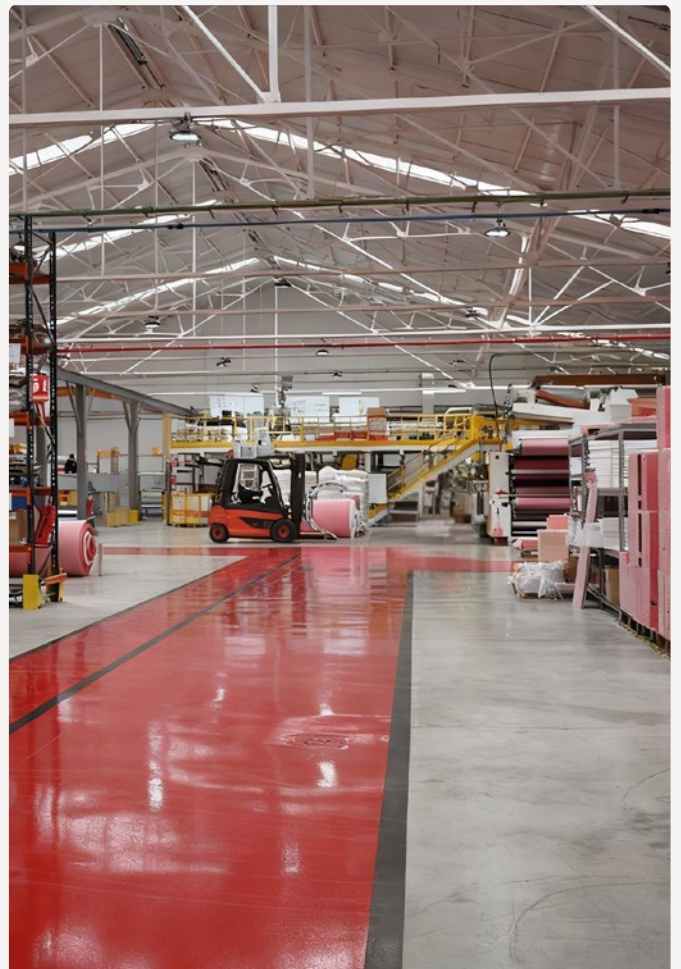

Our point of convergence:
where innovation aligns
with functionality.

Seamless. Limitless.



We design complete systems that ensure long-lasting waterproofing, optimising the installer's work and guaranteeing the highest quality finish.

01

Technology



We operate with a global logistics and production structure in which all our waterproofing systems and accessories are developed to the highest standards, supported by international certifications such as IAPMO, CSTB and KIWA.

This constant evolution allows us to deliver absolute reliability from Europe to the USA, protecting every project with maximum strength and consistency.

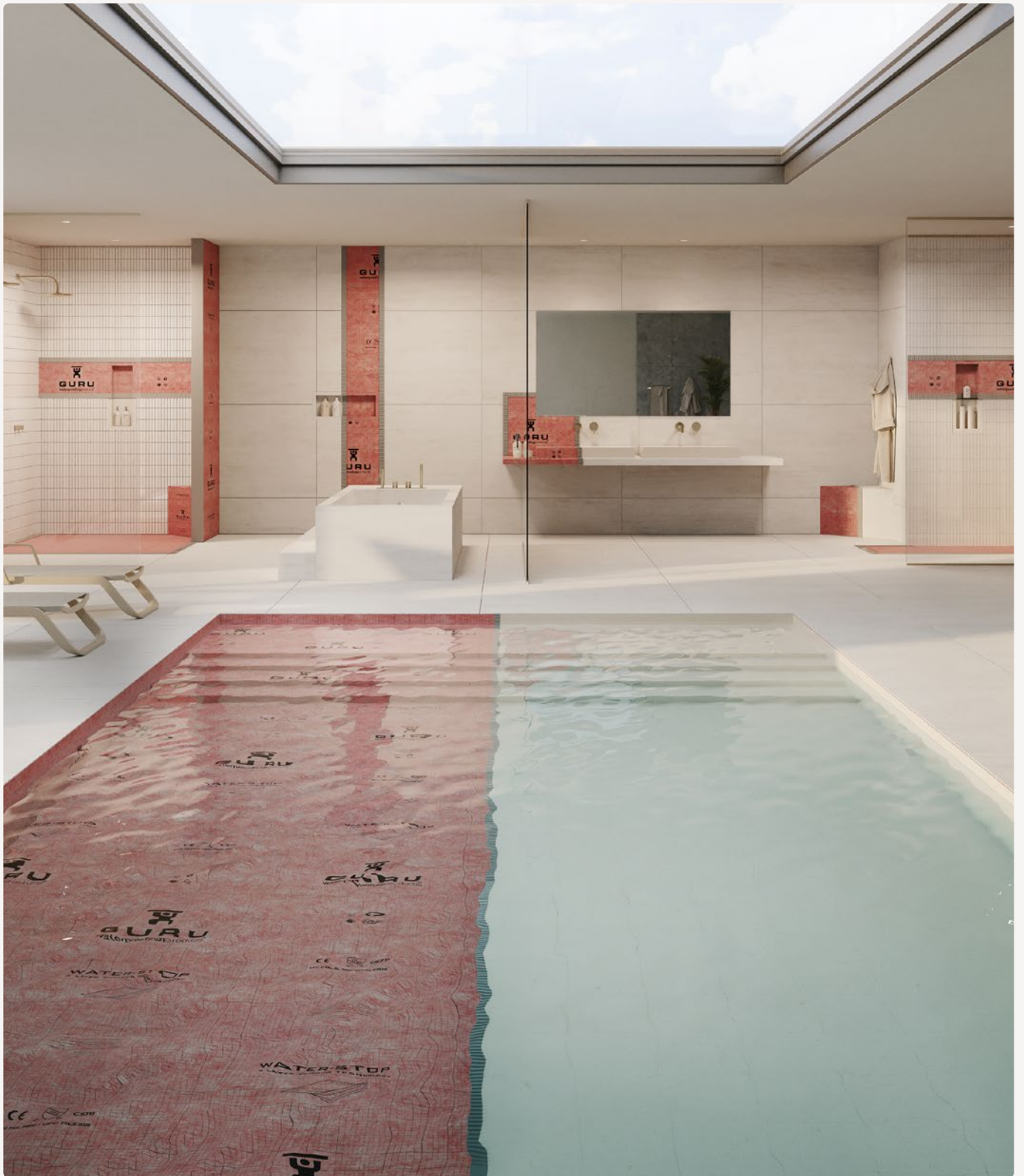

We take our precision even further.
A technique backed by the world's
most demanding standards

02

Innovation



Innovation is our vocation and technology our inspiration.

The distinctive value of our solutions lies in anticipating needs, in the agility with which we develop ideas, and in our in-house production capability to bring them to market. **With guarantees.**

Ideas, attitude and vision.
We are the evolution driving the
future of waterproofing.



03

Exclusivity



We support our clients as a partner that brings judgement, process expertise and quality in the final result.

With the drive of major manufacturers and the closeness of a family business.

We give our solutions a distinctive identity, turning waterproofing into a mutual commitment.

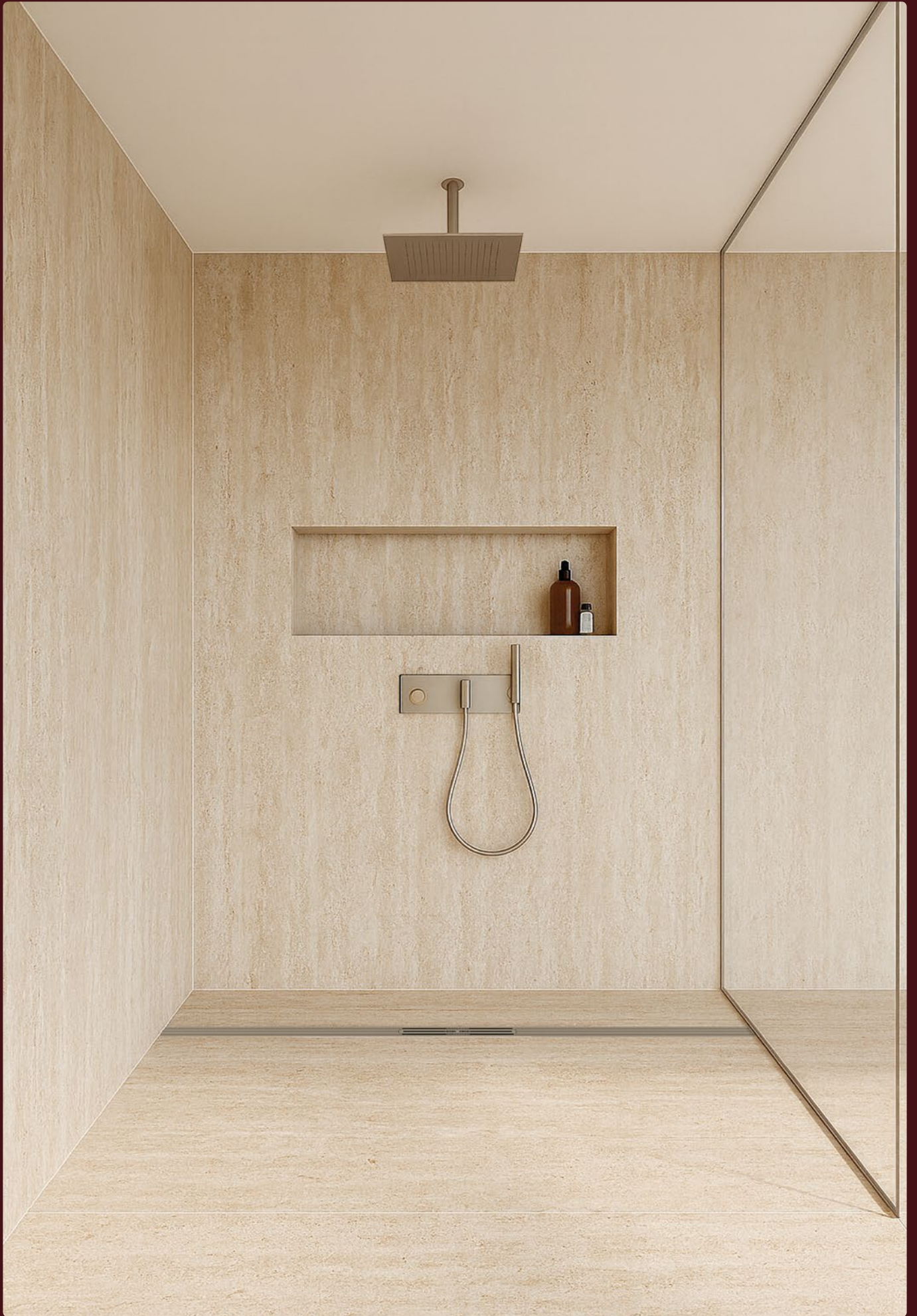

Engineering

We design complete systems tailored to the waterproofing architecture of each project.



Technical rigour

Our solutions are backed by the most demanding international standards.

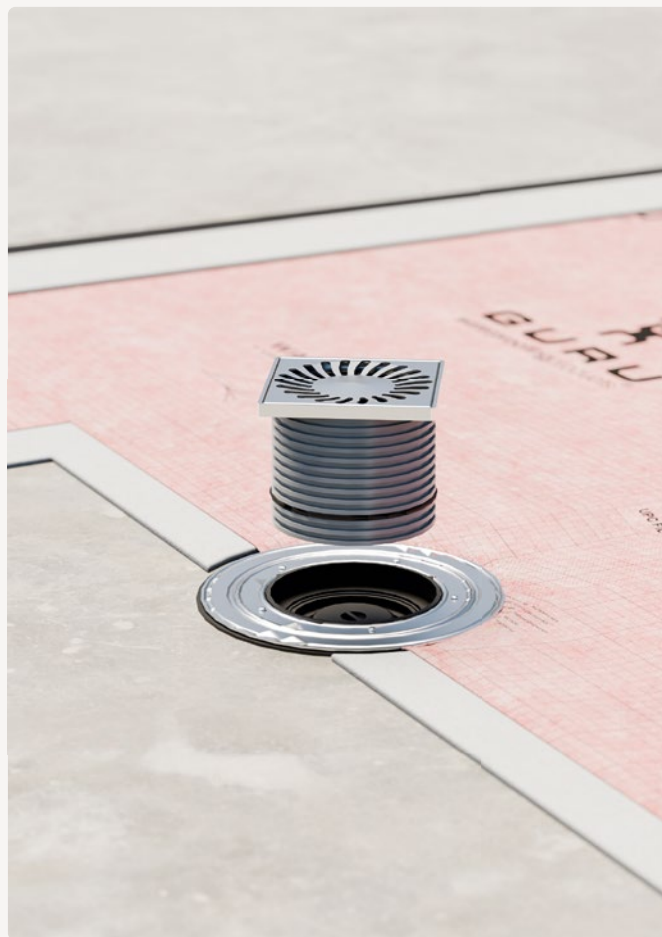

Our distinctive value

Effectiveness

We listen to and meet the installer's needs for a faster, more efficient and safer installation.



Scalability

We continue expanding our industrial capacity to respond to new challenges across multiple markets.





Operational core

We have an infrastructure in constant evolution and growth, designed to optimise every process.

Leadership backed by results

+25

Years of manufacturing experience

+50k

Membrane rolls manufactured each year

Industrial capacity and know-how

20k m²

Production and logistics facilities

100%

In-house technology and proprietary design

A consolidated international presence, built on our impeccable track record and driven by a global network of trust.

+45

Countries trust our waterproofing systems.

+10k

Projects developed in the international market.





A new space, a unique opportunity to scale the future of waterproofing.



We are opening a new chapter with the **expansion of our logistics centre**. The hub where technology, talent and operational strength come together in pursuit of maximum performance.

We are multiplying not only our facilities, but also our responsiveness, positioning ourselves as the perfect partner for your most demanding projects. Creating a lasting experience. **Seamless. Limitless.**



GURU Academy

Our own training platform
for installers

Demos / Training

We take our knowledge directly into action. We travel worldwide to deliver practical, dynamic training sessions tailored to the real challenges of everyday work.



More than training, it is a strategic partnership: we provide installers with the judgement, technique and support of a global brand so they can optimise resources, maximise their time and improve their finishes.

GURU Certification

We endorse your professionalism. Upon completing our programmes, you become an official GURU-certified installer, a seal of guarantee and prestige for your clients.



Business Opportunity

We connect demand with talent by assigning projects and jobs directly to our certified installers according to their service area, with the aim of growing together.





Technical Membranes

01 Corporate Brochure

02 Technical Membranes

03 Drainage Systems

04 Modular Systems

The success of a project is built from within. At GURU, innovation is placed at the service of structure to create a protective membrane that guarantees performance and durability under the most demanding conditions.



GURU
waterproofing products

WATER-STOP

GURU
waterproofing products

CE GBC
ISO 9001:2015

GURU
waterproofing products

Product Index

Innovation is our reason for being. At GURU, we were pioneers in the design of waterproof EVAC-type membranes manufactured using the combined extrusion method.

Our Waterproof membranes are conceived, designed and manufactured to cover every Waterproof need in a home: outdoor areas, indoor areas and swimming pools.

Technical membranes

Water-Stop P 32-47



W-S TOP P 48-49

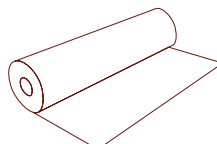

G-Flex P 50-57

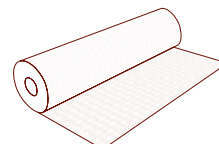

G-Sound / G-Sound Premium P 58-61

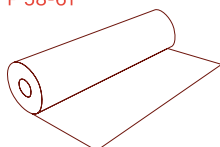

Thermo Seal P 62-63

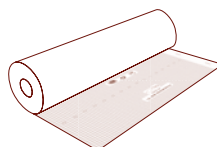

W-S Self-Adhesive P 64-65

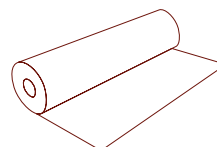

W-S Air P 66-67

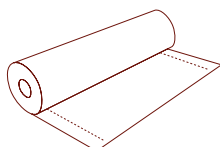

Installation accessories

W-S Tub P 68

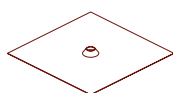

W-S Dex / W-S Din P 68

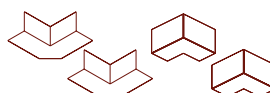

W-S Dex 135° / W-S Din 135° P 68

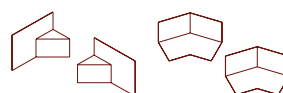

W-S Band 14 / 34 P 68

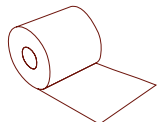

W-S Self-Adhesive accessories P 68

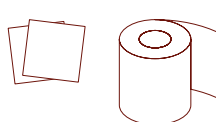

SafeTub P 68

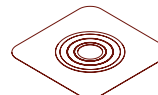

W-S Passtube P 68

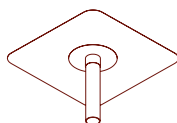

Adhesives P 70



G-Trowel P 71

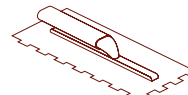

W-Spatula P 71

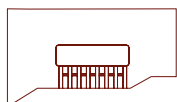

Raynex Premium P 71

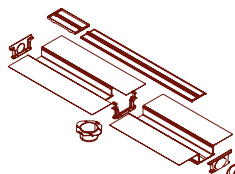

Raynex PVC P 71

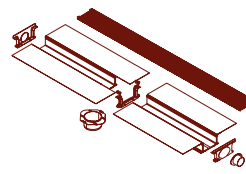



One membrane,
no limits.



Water-Stop

Waterproof membrane



Indoor



Outdoor



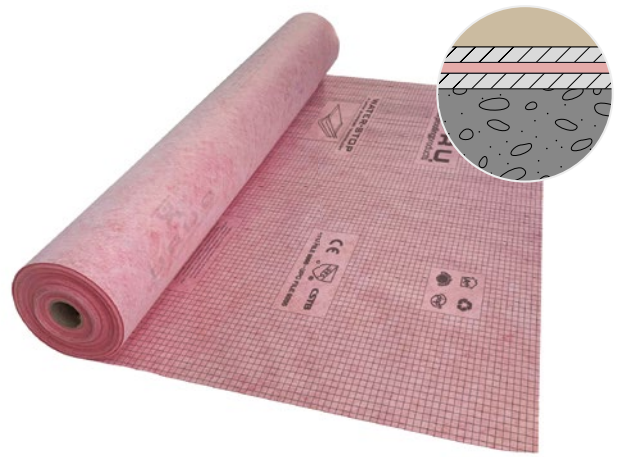

Thickness: 0.55 mm

Water-Stop is an EVAC waterproof membrane manufactured in Spain. It stands out for its multi-layer structure, which makes it capable of Waterproof everything from showers to swimming pools up to 10 meters deep.

Manufactured with **4 layers** technology:

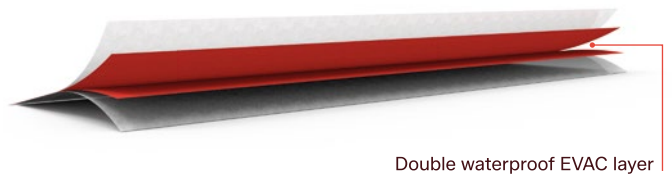

Features



Warranty

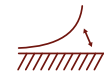

More flexible than most membranes

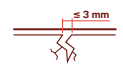

Crack-bridging



Anti-root



Indoor and outdoor use

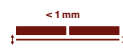

Minimum installation height

Swimming pools

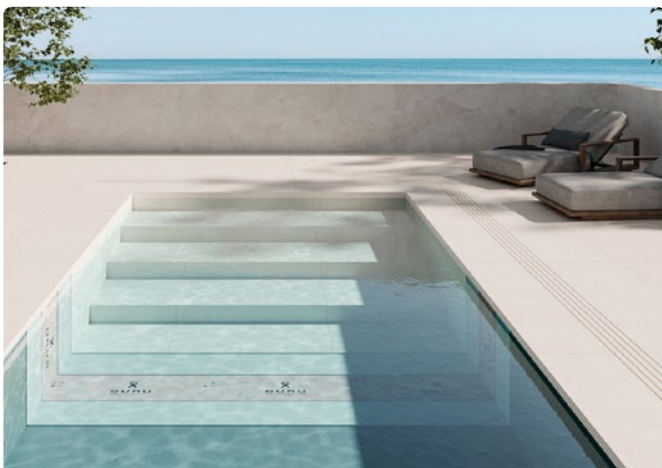

Technical data

Weight/m² (g): 260

Width (m): 1, 1.5, 2, 3

Length (m): 5, 10, 20, 30, 40

Pull-out strength: $\geq 0.7 \text{ N/mm}^2 \geq 70 \text{ tons/m}^2$



Examples of indoor installations

Waterproof of public changing rooms



Ref.	Description	Page	Format
IF52000	Water-Stop Roll 1 x 30 m 30 m ²	40	Roll
IGU6005	W-S Dex	68	Bag 2 units
IGU6006	W-S Din	68	Bag 2 units
IG60004	W-S Tub	68	Bag 2 units
IG61000	W-S Band 14	68	Roll 14 cm x 20 m
IGU6007	Mixing valve seal	-	Bag 1 unit

Shower Waterproof



Examples of outdoor installations

Terrace Waterproof

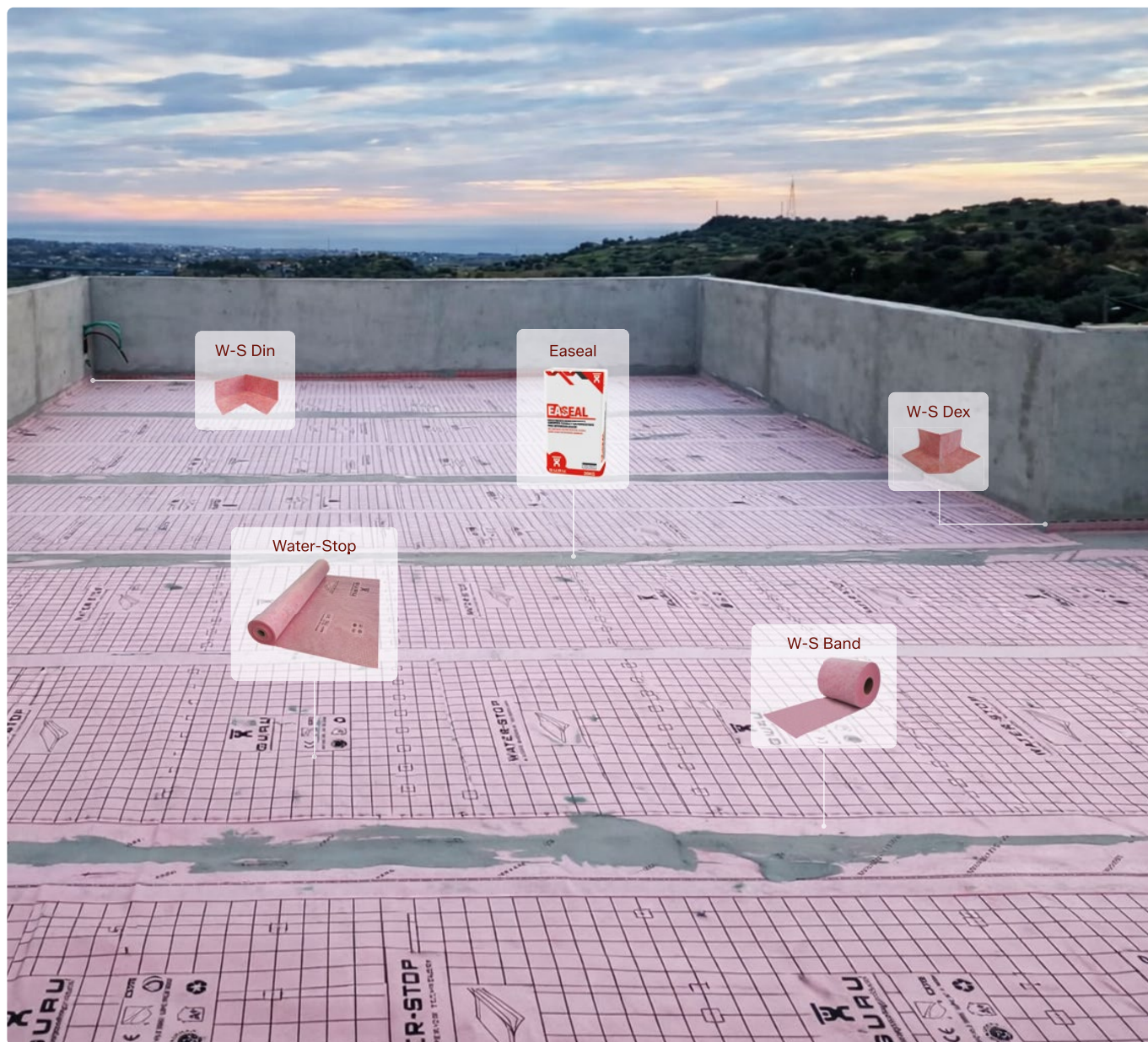

Ref.	Description	Coverage	Page	Format
IF53000	Water-Stop Roll 2 x 20 m · 40 m ²	-	40	Roll
IGU6005	W-S Dex	-	68	Bag 2 units
IGU6006	W-S Din	-	68	Bag 2 units
IF56024	W-S Passtube 110 mm (gargoyle) *1	-	68	1 pc
IG61000	W-S Band 14	-	68	Roll
IG60023	Easeal 20 kg	280 m ² *	70	Bag
IG64000	W-S Mastic 290 ml	6 m	70	Cartridge

*1 See page 68 for more sizes. ►

*2 Coverage for this installation method: 5 cm overlap. See page 70 for more details. ►

Stair Waterproof



Roof terrace Waterproof

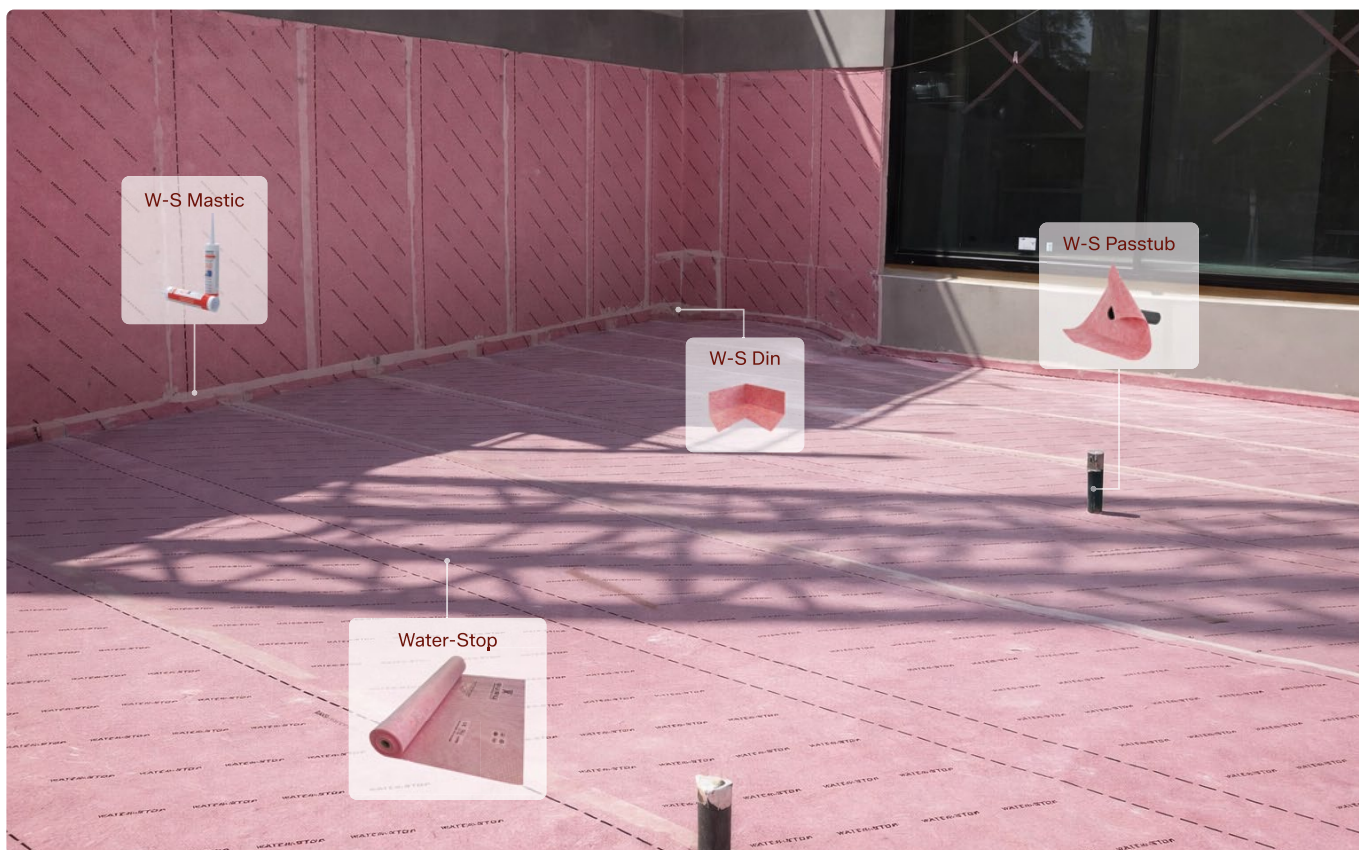

Examples of installation in swimming pools

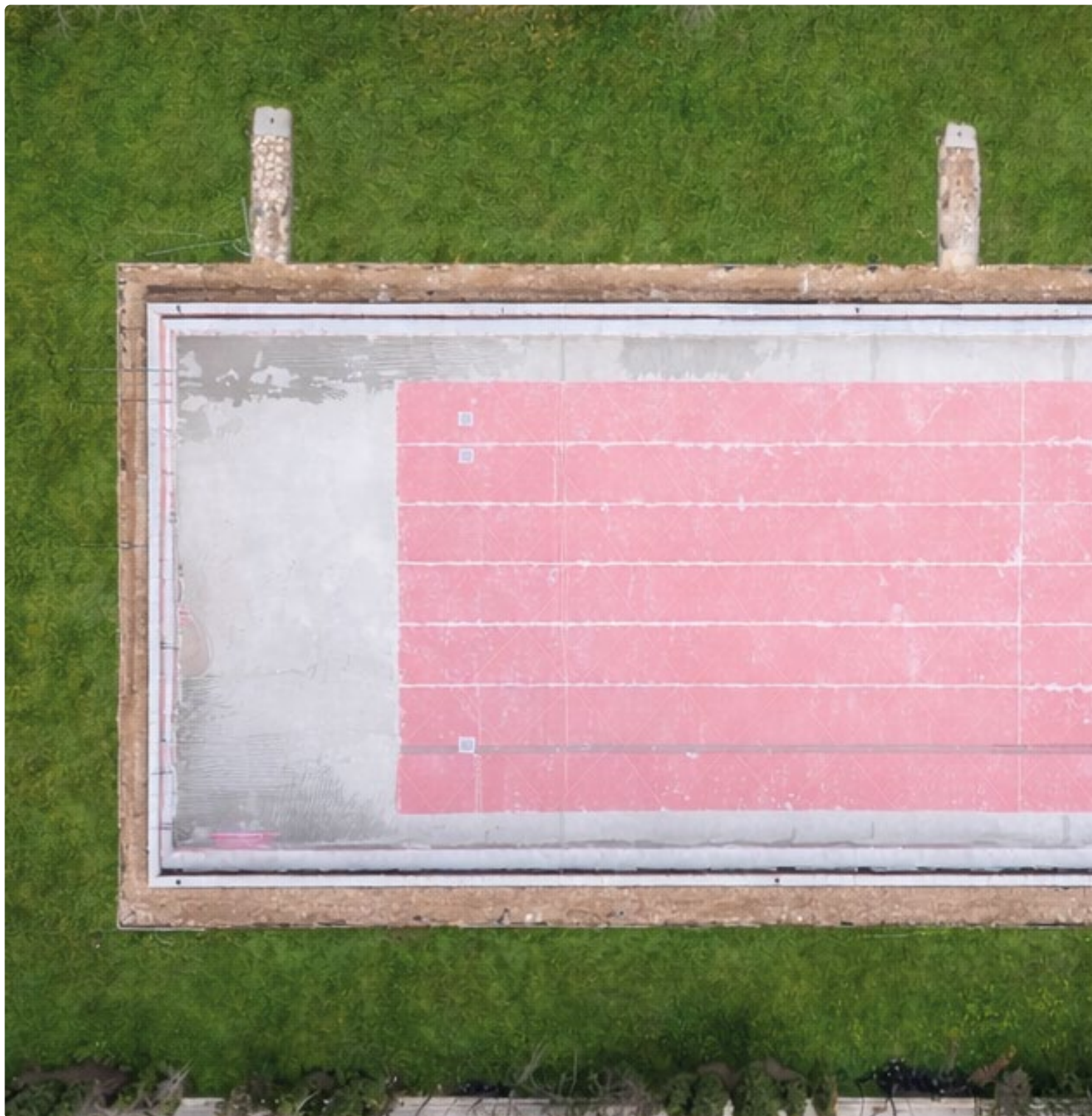

Ref.	Description	Coverage	Page	Format
IF53000	Water-Stop Roll 2 x 20 m · 40 m ²	-	40	Roll
IG60021	Safetub Ø63-75 mm	-	68	Bag 5 units
IG61000	W-S Band 14	-	68	Roll 14 cm x 20 m
IG60023	Easeal 20 kg	120 m*	70	Bag

* Coverage for this installation method: overlap with W-S Band. See page 70 for more details. ►

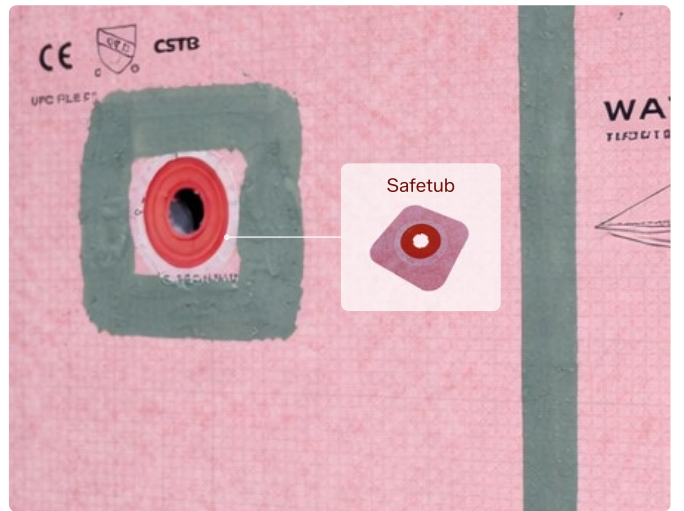
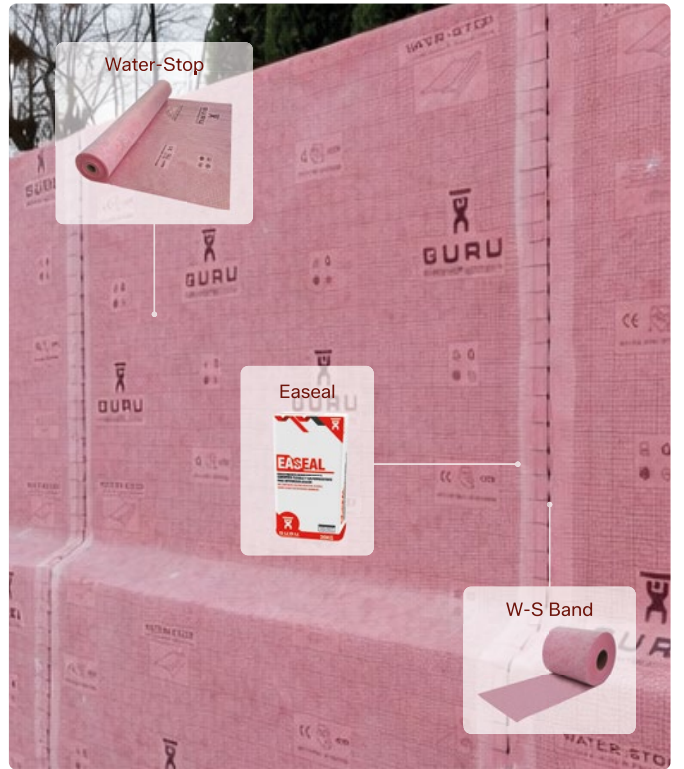

Renovations are no longer a problem

WATER-STOP is a Waterproof membrane only 0.55 mm thick, ideal for renovating terraces and balconies without increasing the existing height. It is installed directly over the existing flooring, solving leaks and moisture problems with a quick and clean installation.

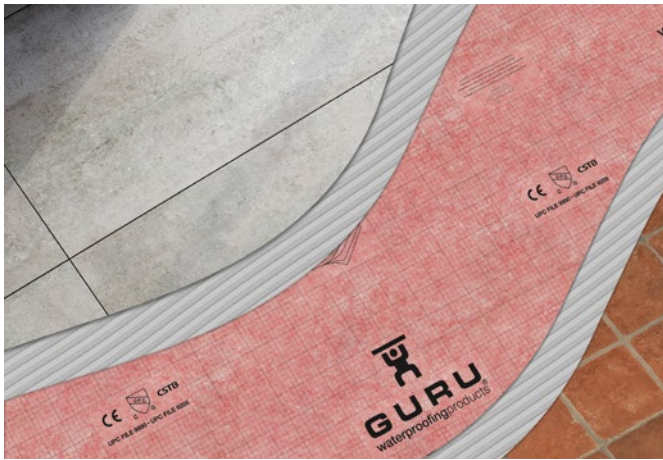

High mechanical grip

Its excellent adhesion allows it to be fixed directly to the substrate and the covering to be applied over the membrane without a compression layer, ensuring a firm and withtinuous installation on both floors and walls.



Protection against movement

The elasticity of the membrane and its fibers allows it to absorb small expansions and cracks, preventing stress between the substrate and the covering.

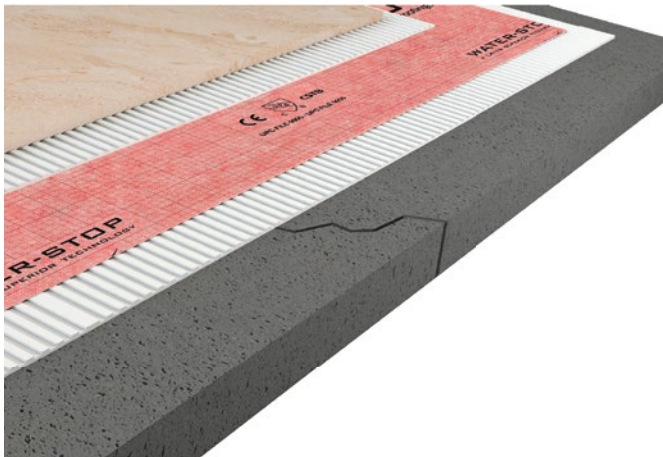

Maximum adaptability

Its high flexibility makes it easy to waterproof complex areas such as corners, edges or floor-to-wall junctions, ensuring a withtinuous and watertight finish..

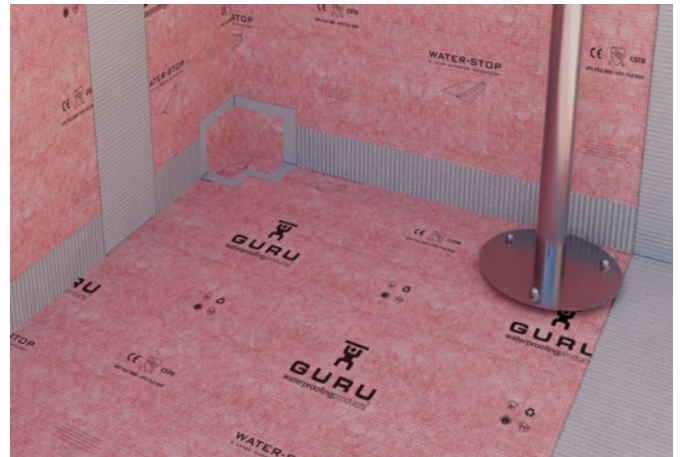

Product			Logistics		
Ref.	Description	Size	Weight/Roll	Units/box	Units/pallet
IF55039	Water-Stop Bag	1,5 x 2 m 3 m ²	1 kg	-	-
IF51000	Water-Stop Roll	1 x 5 m 5 m ²	1,6 kg	12	200
IF51013	Water-Stop Roll	1 x 10 m 10 m ²	3,2 kg	10	200
IF52000	Water-Stop Roll	1 x 30 m 30 m ²	8,7 kg	4	100
IF54000	Water-Stop Roll	1,5 x 20 m 30 m ²	8,7 kg	5	100
IF53000	Water-Stop Roll	2 x 20 m 40 m ²	11,7 kg	4	100
IF63000	Water-Stop Roll	3 x 20 m 60 m ²	15,6 kg	4	100
IF53040	Water-Stop Roll	2 x 40 m 80 m ²	23,4 kg	2	-

When format makes the difference.

- + Larger formats
- + Greater adaptability
- Waste
- Joins
- Risk



Why choose Water-Stop?

Analysis of general Waterproof methods

Water-Stop

Multi-layer EVAC membrane designed for under-tile installations. It is bonded using C2 S1 adhesive mortar.

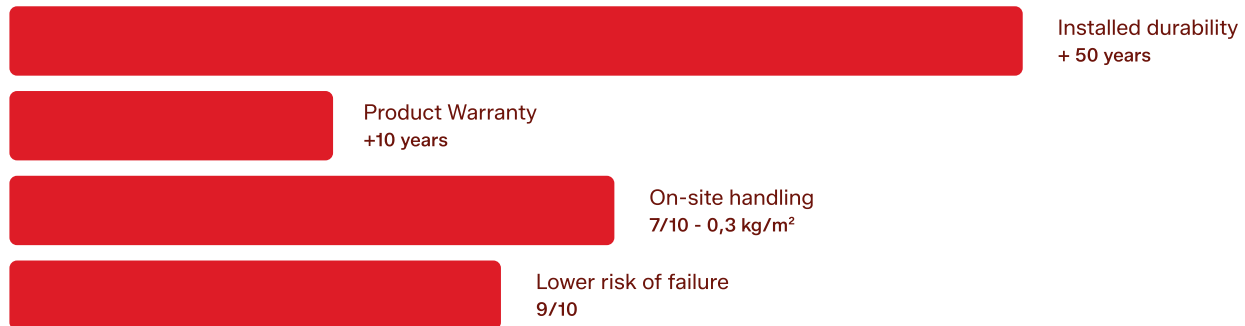

Asphaltic

Membranes manufactured by impregnating paper or glass fibre mat with pitch or bitumen and adding plasticisers.

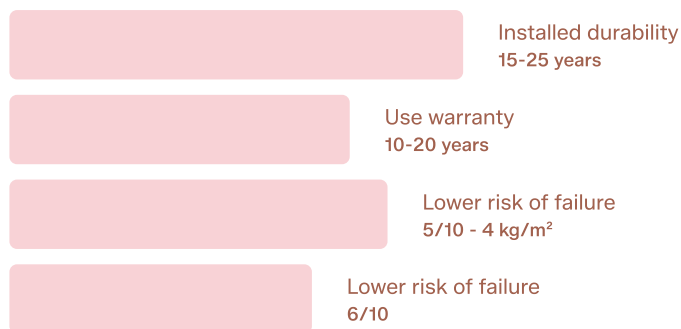

Liquid application

Products made from polymers in solution. They may be rubber-based or polyurethane-based, polyureas or waterproof cements.

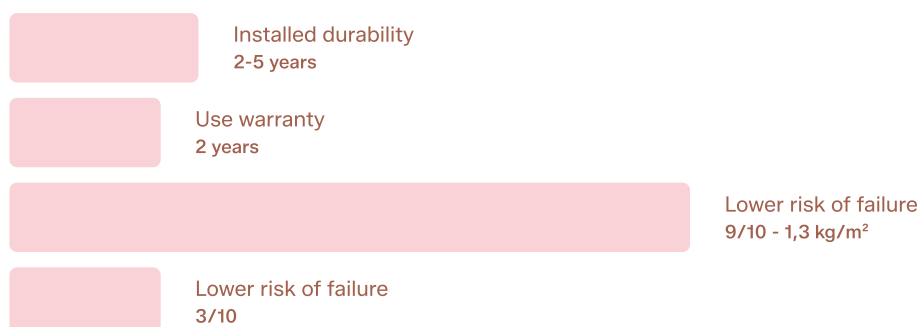

Installation characteristics

Height of installation

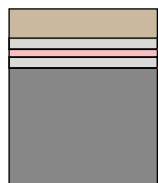

Total height	0,3 cm
Weight	25-30 kg/m ²
Time	20 min/m ²
Total time	Same day

Sustainability

High Sustainability



0,25 kg/m² of recyclable plastics



Low waste



Low toxicity



Resources required



Height of installation

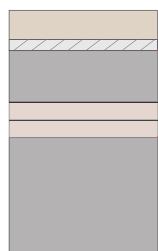

Total height	7 cm
Weight	120-180 kg/m ²
Time	50 min/m ²
Total time	3-5 days

Sustainability

Low Sustainability



4 kg/m² of non-recyclable material



Low waste



Medium toxicity



Resources required



Height of installation

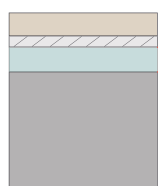

Total height	0,5 cm
Weight	30-35 kg/m ²
Time	35 min/m ²
Total time	2-3 days

Sustainability

Low Sustainability



1,3 kg/m² of non-recyclable material



High waste



High toxicity



Resources required



Why choose Water-Stop?

Analysis of general Waterproof methods

Source: 

Based on the analysis of the different variables that influence the total installation cost of a Waterproof system, including product price per m², labour cost and installation time, we can state that the installation of the WATER-STOP membrane requires less time and less labour.

This results in improved overall site productivity and a significant reduction in the final project cost.

Water-Stop



Asphaltic



Liquid application

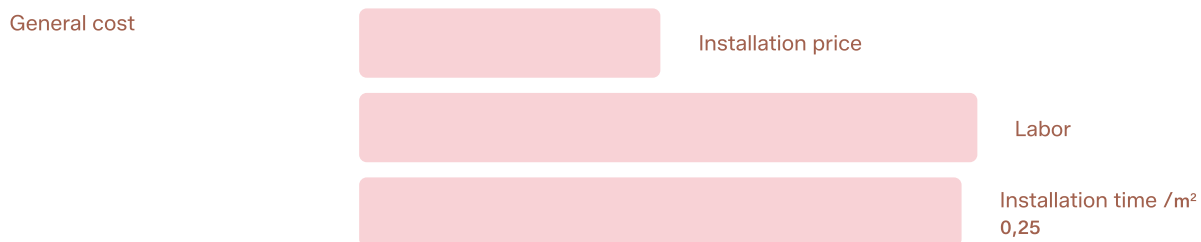

With GURU cost is always reduced.

Thanks to an optimised design and systems conceived for fast and efficient installation, GURU solutions reduce the costs associated with the project.

Save up to **43,6%**



Less plastic, more protection.



Thanks to our unique multi-layer structure in Water-Stop, we have significantly reduced the amount of plastic required to manufacture our membranes. GURU has a rigorous EPD analysis to demonstrate this.

The **Environmental Product Declaration** is a rigorous analysis that evaluates the environmental impact of a product throughout its life cycle. We not only seek excellence in performance, but also to achieve it with transparency.



More than a certification, an environmental commitment.

Climate efficiency



Resource savings



Environmental commitment



Environmental preservation



W-S Top

Membrane
for flat roofs



Product

Ref.	Description	Size
UV71000	W-S TOP Roll	1,5 x 20 m · 30 m ²
UV74000	W-S TOP Roll	3 x 20 m · 60 m ²



Thickness: 1.5 mm

UV-resistant waterproof membrane manufactured with a multilayer thermoplastic polyolefin structure and a polymer fibre backing for excellent adhesion with cement-based adhesives such as C2 tile adhesive. Suitable for applications requiring a waterproof membrane exposed to weathering. Produced in high-reflectance white in accordance with cool roof standards.

Composition:



Multilayer structure for top protection

Features



Warranty



Outdoor exposed use,
weather-resistant



Heat reduction



Heat-welded
overlaps



Reflective for
maximum efficiency



UV-resistant

Technical data

Weight/m² (gr): 800

Width (m): 1'5, 3

Length (m): 20

G-Flex

Uncoupling
membrane



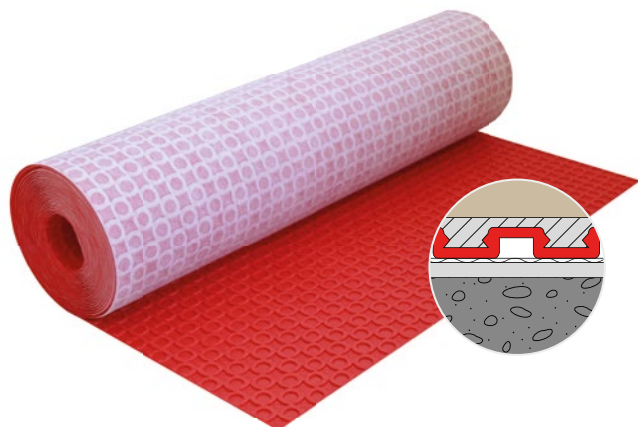

Thickness: 3 mm

G-Flex is an **anti-fracture uncoupling and waterproof** membrane that protects floor coverings on new, old, damp, dry, cracked or dimensionally unstable substrates.

It helps **reduce construction times**, as installation and tile laying can be carried out immediately, and the surface is instantly walkable. It also improves the performance of underfloor heating systems thanks to its cavities, which distribute heat evenly.

Its high capacity to release moisture from the slab in new-build construction allows ceramic tiles to be installed in less than 28 days, reducing waiting time by up to two weeks. This same property makes it ideal for renovations in damp areas or those exposed to rain.

Structure

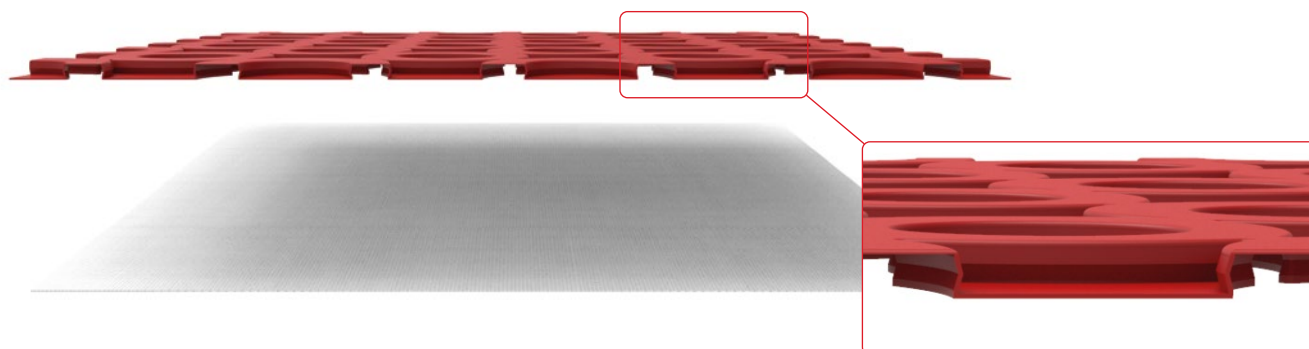

Features

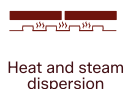
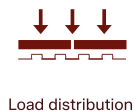

Technical data

Weight/m² (gr): 550
 Width (m): 1
 Length (m): 14, 30
 NAIL - Mechanical fastening
 Pull-out strength: $\geq 0.7 \text{ N/mm}^2 = \geq 70 \text{ tons/m}^2$
 Robinson Floor Test - Extra Heavy

Product			Logistics	
Ref.	Description	Size	Units/box	Units/pallet
ILU5100	Roll G-Flex	1 x 14 m · 14 m ²	1	20
ILU5200	Roll G-Flex	1 x 30 m · 30 m ²	1	12

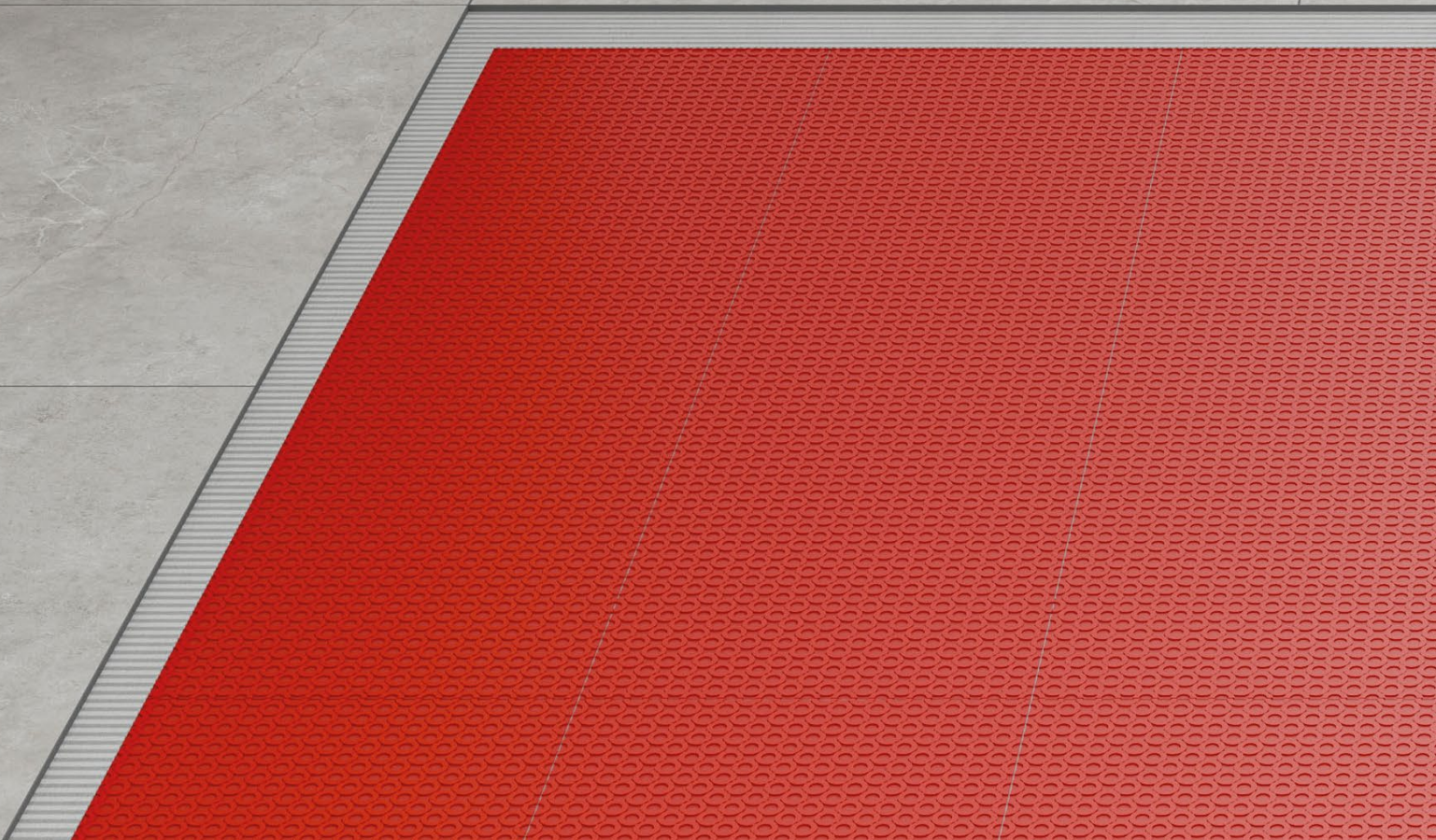

Maximum protection, zero breakages.

Waterproofs the substrate,
protects the tiling.

The G-Flex membrane stands out for its load-distribution capacity, protecting the finish on large surfaces such as terraces, plazas or trafficable areas such as car parks and dealerships.

This advantage is particularly useful in large-format, reduced-thickness ceramic tile installations.

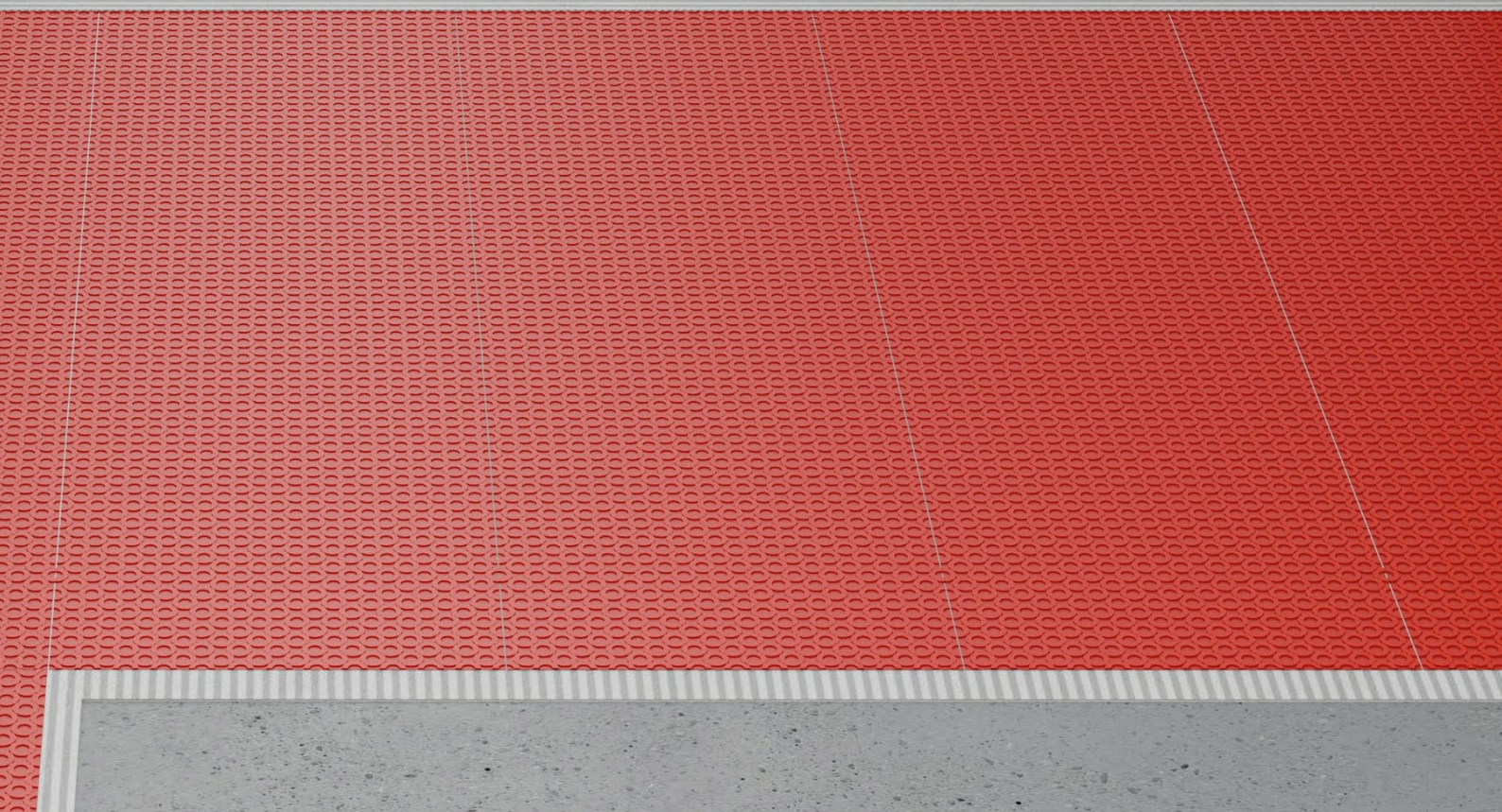

Examples of Waterproof with G-Flex

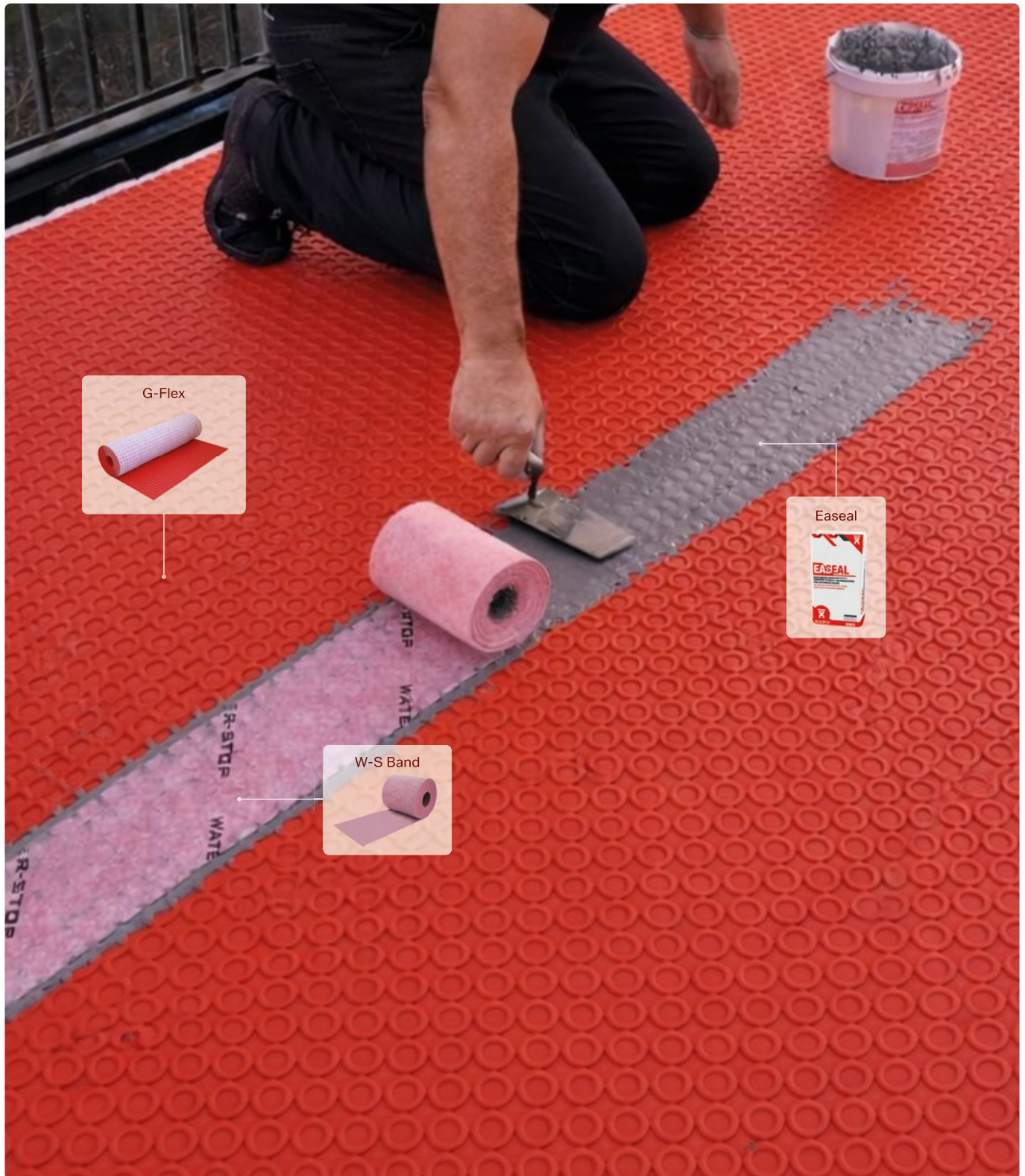

Ref.	Description	Coverage	Page	Format
ILU5200	Roll G-Flex 1 x 30 m · 30 m ²	-	51	Roll
IG61000	W-S Band 14	-	68	Roll 14 cm x 20 m
IG60024	Easeal 3 kg	9 m*	70	Bucket

*Coverage for this installation method: overlap with W-S Band. See page 70 for more details. ►

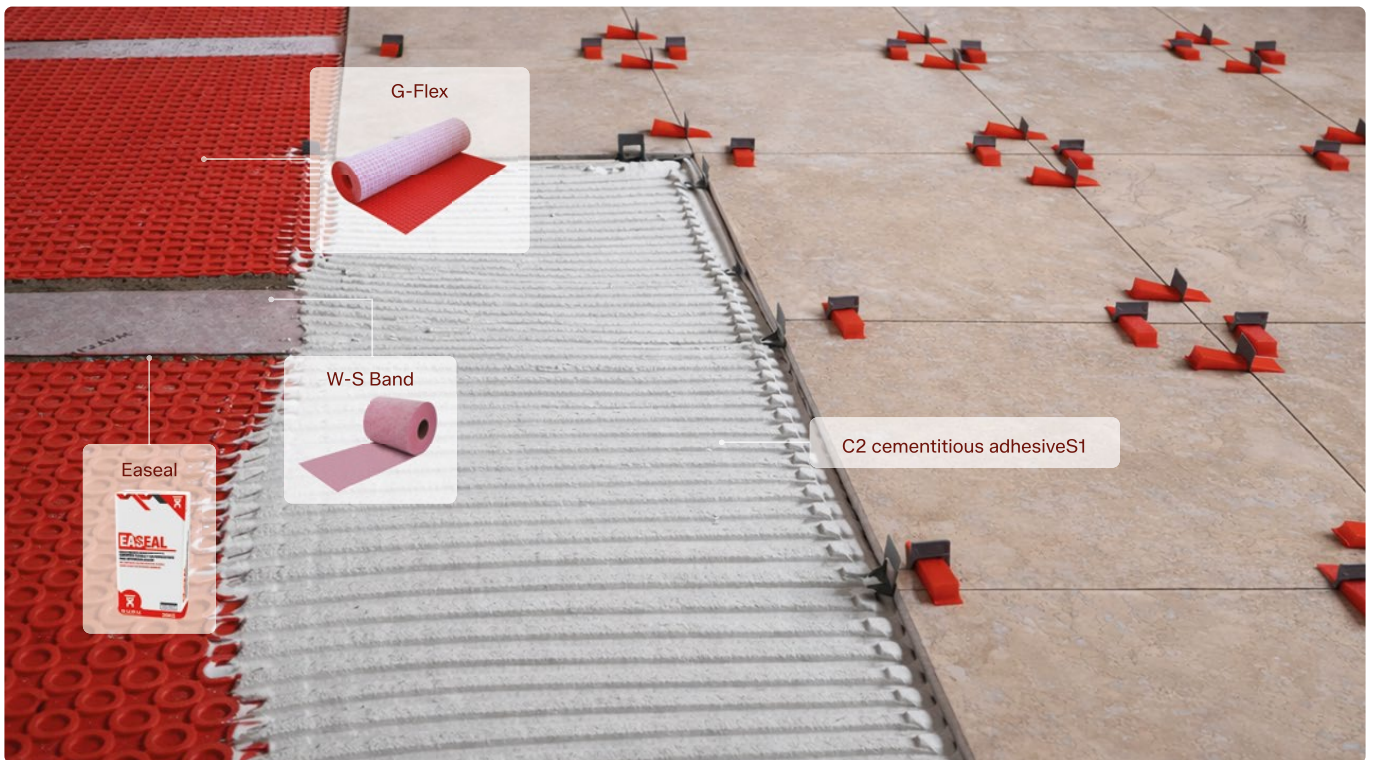
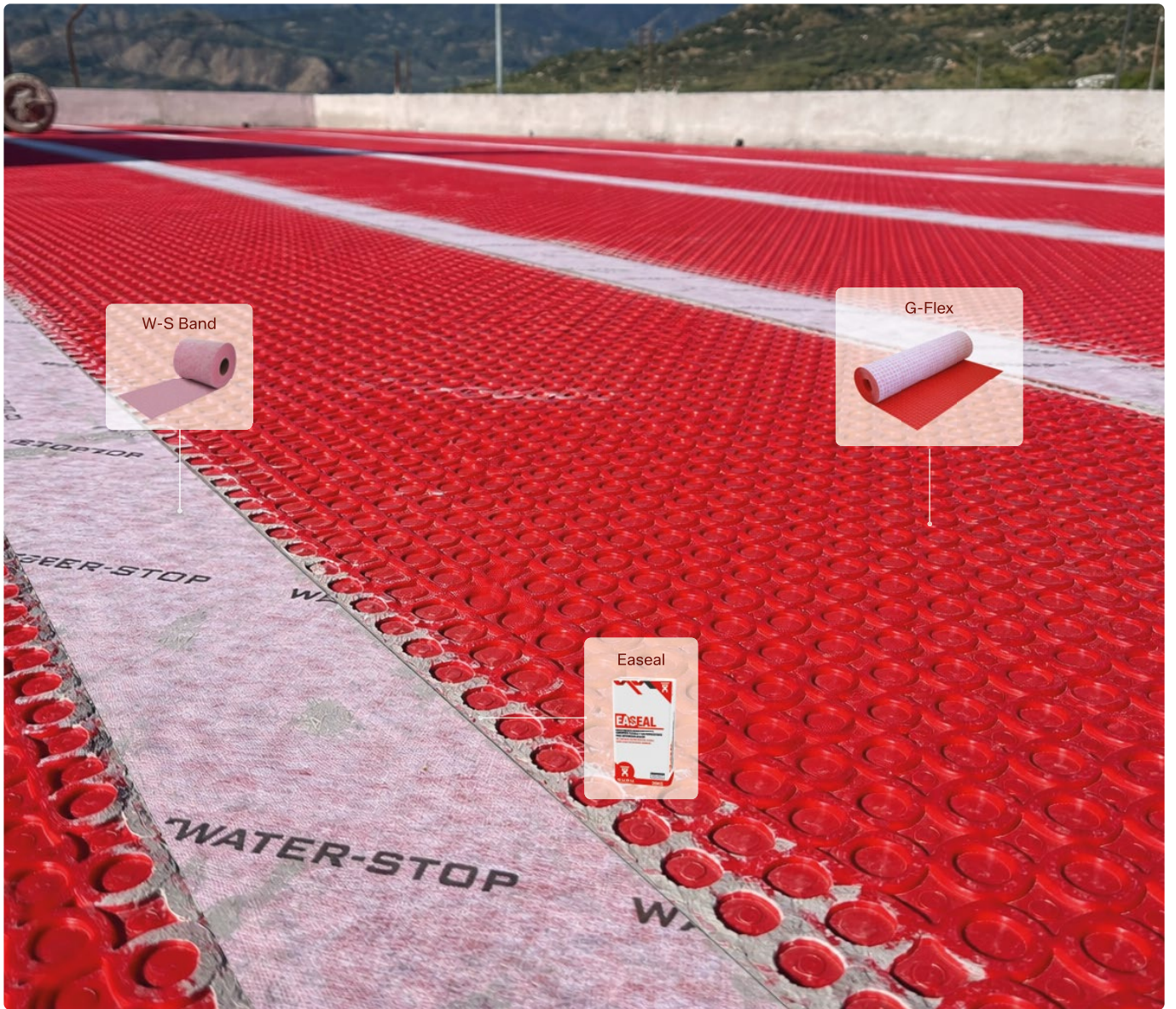

Installation against negative pressure moisture and rising damp

Moisture caused by negative hydrostatic pressure occurs when groundwater penetrates from the outside of the building towards the Indoor, generating damage such as debonding of the finish, mould growth or unpleasant odours. This phenomenon is common in buried walls, garages or basements in contact with embankments or areas with a high water table

G-FLEX provides an effective solution against negative-side moisture, since the cavity formed between the waterproof membrane and the substrate **allows moisture to dissipate into the air**, preventing build-up and protecting the structure.

Negative-side moisture with ceramic finish

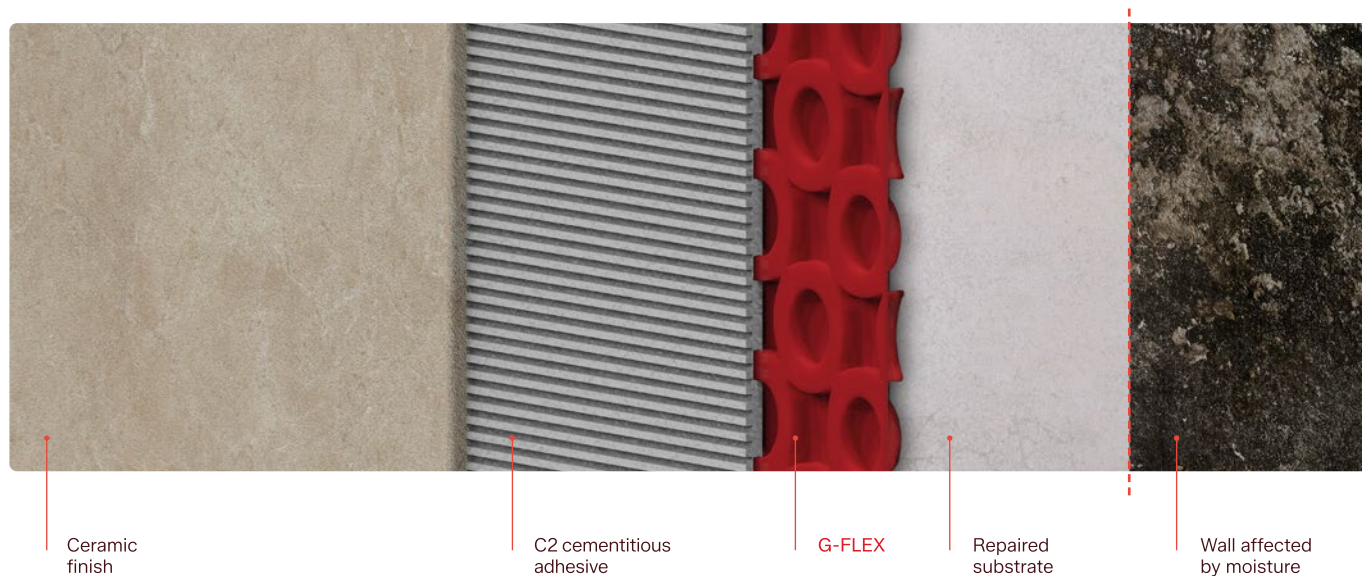

Negative-side moisture with rendered and painted finish

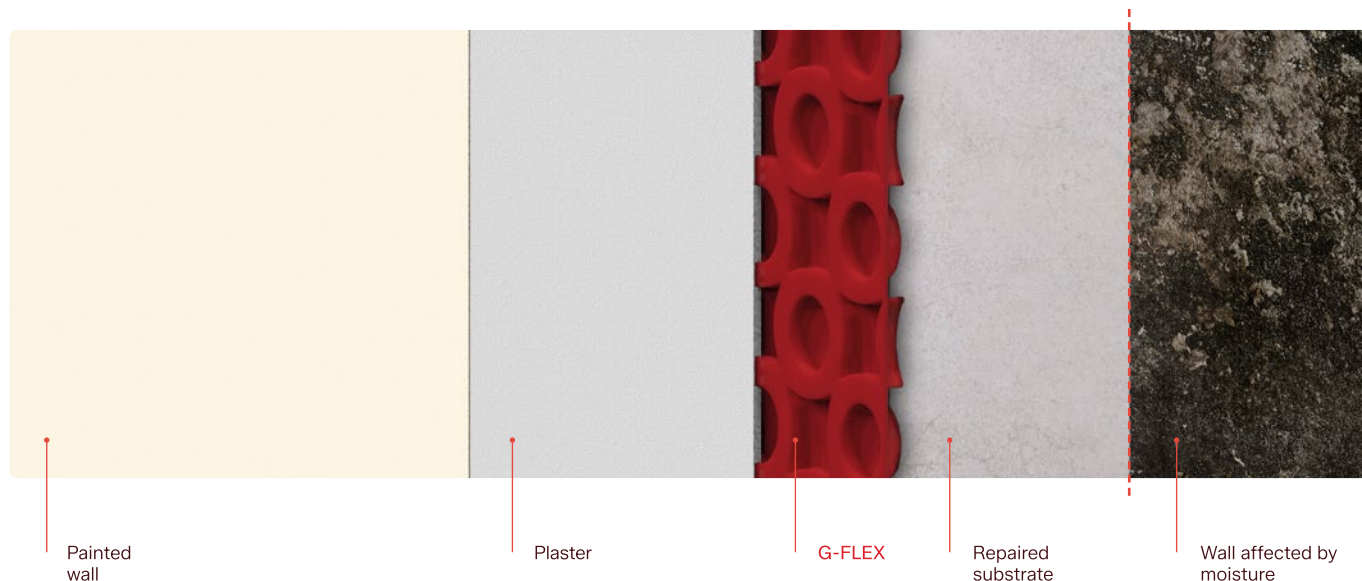

Ref.	Description	Format
IG68000	G-Washer (pack 250 washers)	Box

It is recommended to use screws 5/6 mm thick together with wall plugs suitable for the type of wall.

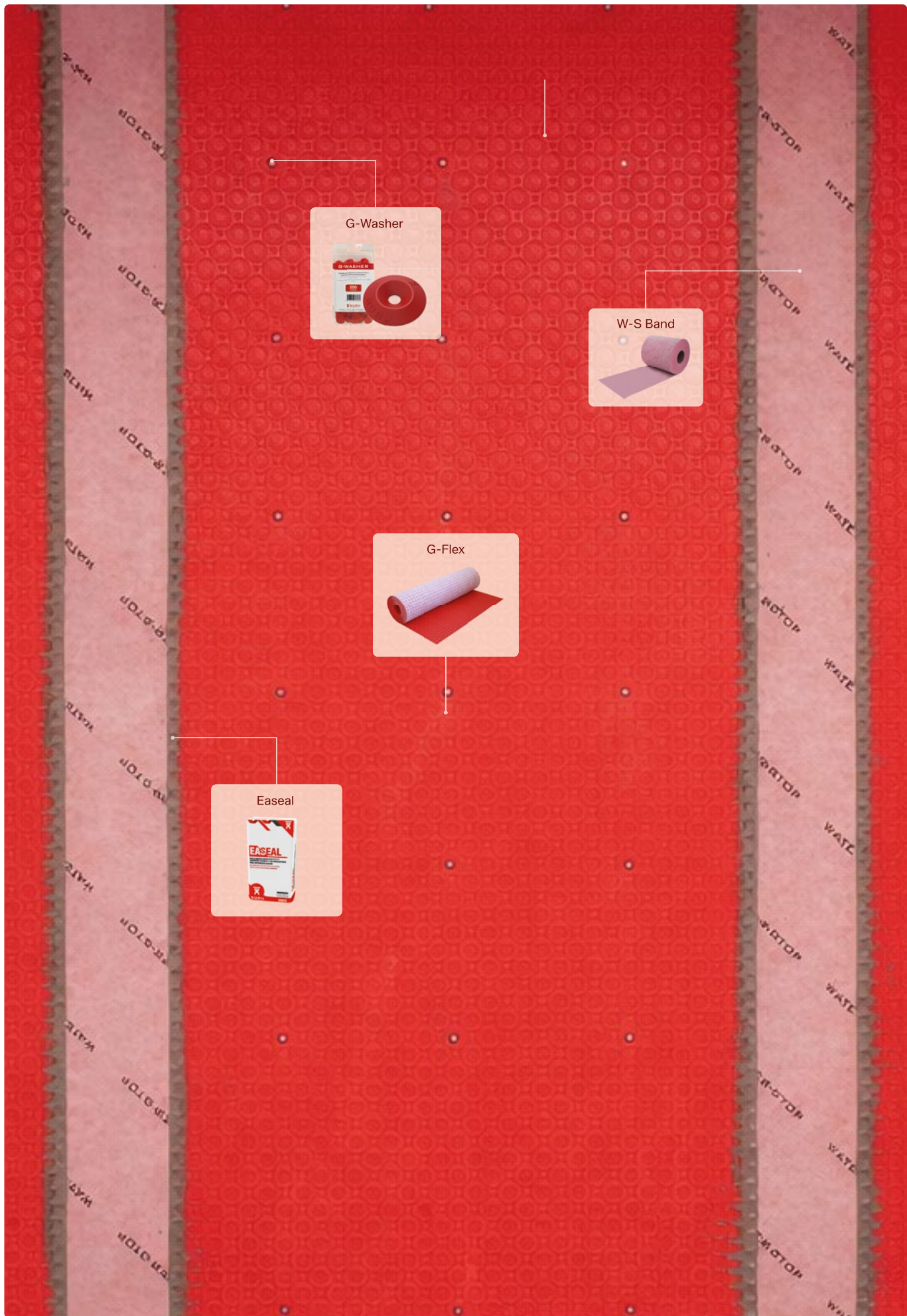

G-Sound

Impact sound insulation membrane

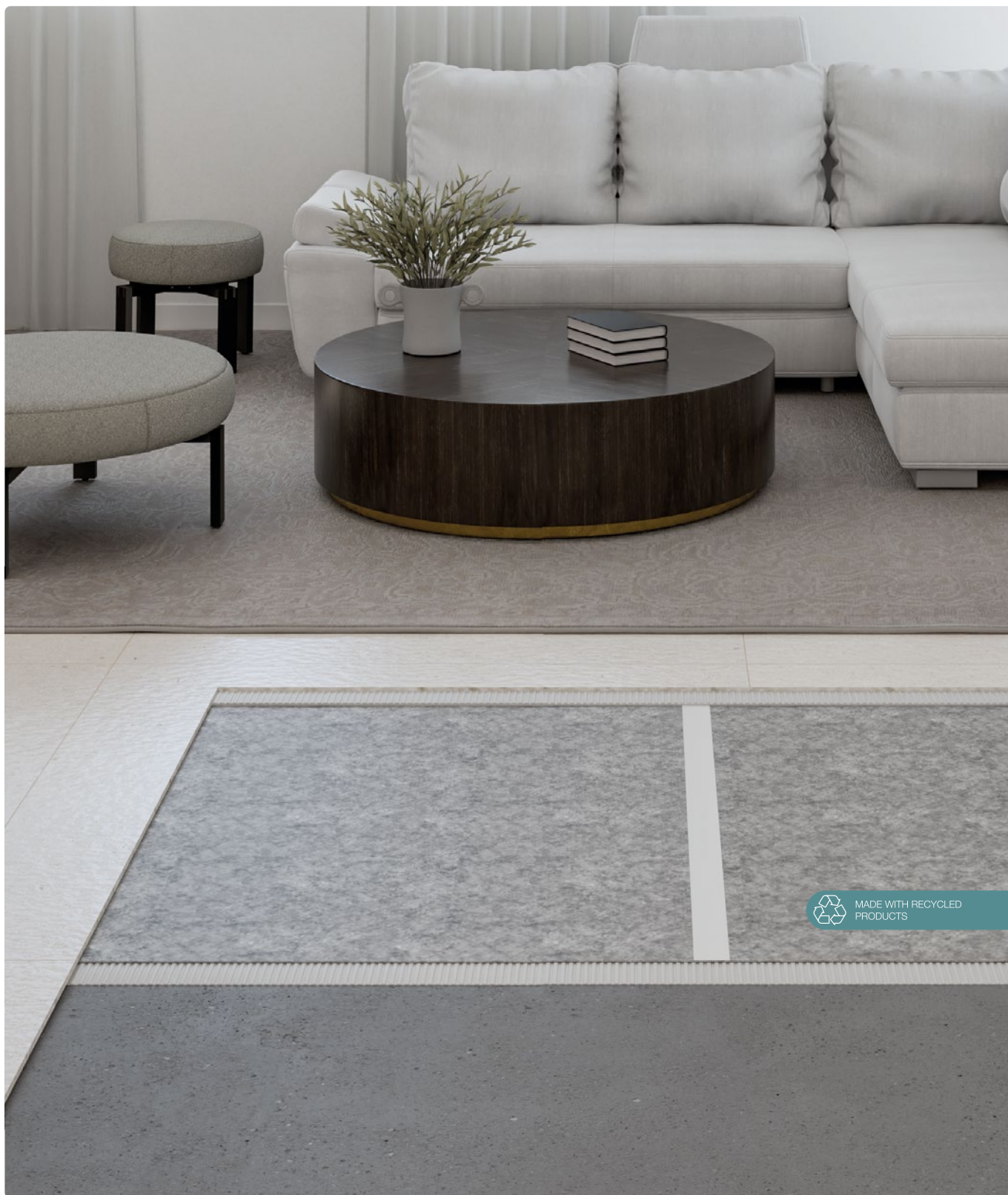

Product			Logistics	
Ref.	Description	Size	Units/box	Units/pallet
IU70000	Roll G-Sound	1 x 30 m · 30 m ²	1	60

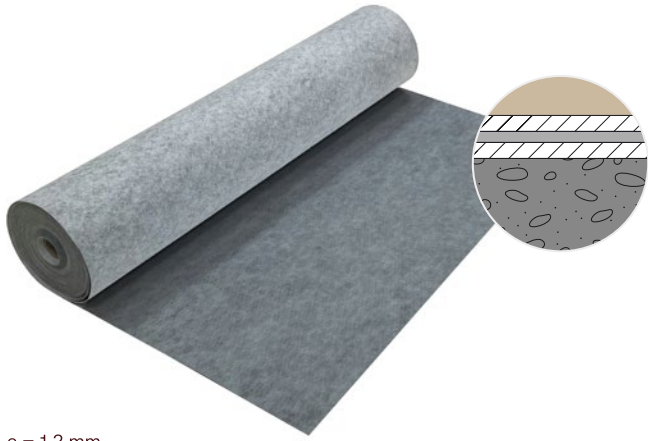

e = 1,2 mm
Installed with C2 cementitious adhesive: total thickness = 3.5 mm

The G-Sound membrane range is designed to **reduce impact sound** by 15 to 20 dB, while also acting as a moisture barrier thanks to its **Waterproof properties** and protecting the finish against structural movement due to its **uncoupling** function.

Its **reduced thickness and fully bonded installation** eliminate the need for thick mortar layers, resulting in a total build-up of less than 1 cm, ideal for low-profile floor systems. This combination makes it an optimal solution for both new-build and refurbishment projects.

Features



Warranty



Instant 15 dB reduction



Waterproof and uncoupling



Suitable for all types of finishes



High compressive strength *

Technical data

Weight/m² (gr): 440

Width (m): 1

Length (m): 30

Manufactured from recycled materials

Impact sound reduction up to 15 dB

Technical data

Calculations according to UNE-EN ISO 12354-2: 2018

Reduction in impact sound transmission level ΔL under floating floor::

F (Hz)	ΔL (dB)			F (Hz)	ΔL (dB)		
	S01	S02	S03		S01	S02	S03
100	-9,1	-31,0	-25,0	800	18,0	5,1	11,1
125	-6,2	-27,2	-21,1	1000	20,9	9,0	15,0
160	-3,0	-22,9	-16,8	1250	23,8	12,8	18,9
200	-0,1	-19,0	-13,0	1600	27,0	17,1	23,2
250	2,8	-15,1	-9,1	2000	29,9	21,0	27,0
315	5,8	-11,1	-5,1	2500	32,8	24,9	30,9
400	9,0	-7,0	-0,9	3150	35,8	28,9	34,9
500	11,9	-3,1	2,9	4000	39,0	33,0	39,1
630	14,9	0,9	7,0	5000	41,9	36,9	42,9

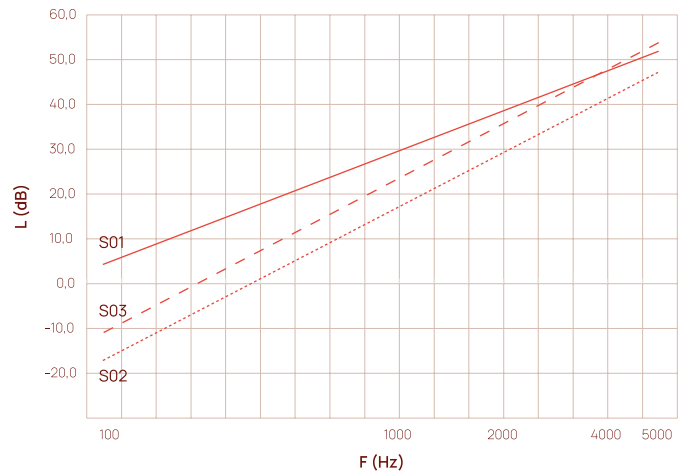

Reduction in impact sound transmission level ΔL under floating floor::

S01: Floating screed made of mortar	ΔL_w (dB) 15,2	m' (kg/m ²): 220	f ₀ (Hz): 201
S02: Dry floating floor (gypsum board)	ΔL_w (dB) 8,1	m' (kg/m ²): 25	f ₀ (Hz): 597
S03: Dry floating floor (wood)	ΔL_w (dB) 6,3	m' (kg/m ²): 50	f ₀ (Hz): 422

Reduction in impact sound **15,2 dB**

G-Sound Impact sound insulation membrane

PREMIUM

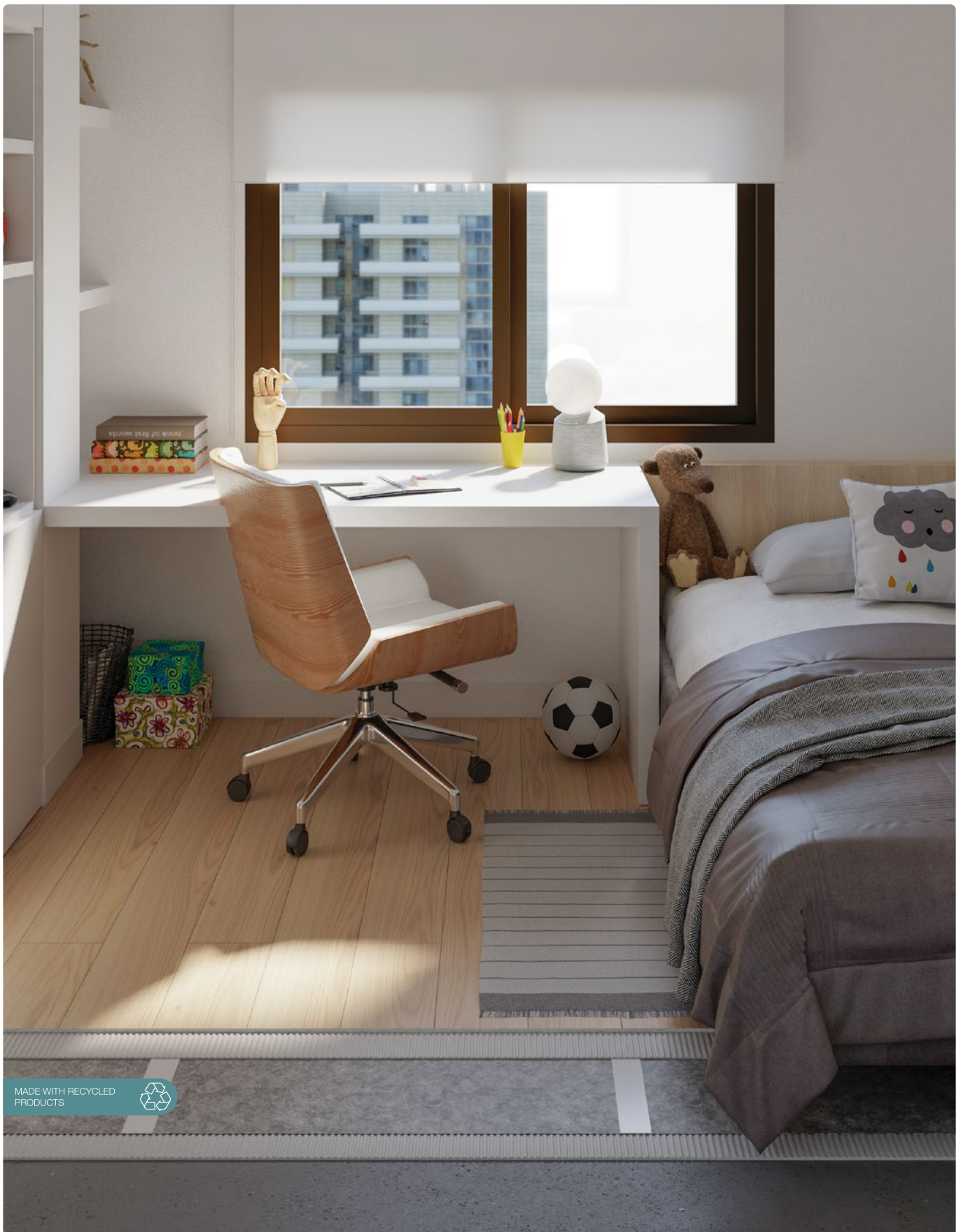

MADE WITH RECYCLED PRODUCTS



e = 2,5 mm / Instalation with C2 cementitious adhesive: e = 4,5 mm

Within the impact sound membrane range, G-Sound Premium is a high-performance solution for reducing impact noise. In addition to incorporating all the properties of G-Sound, it provides **acoustic attenuation of up to 20 dB** with a total thickness of only 2.5 mm. Its 2 x 10 m format enables **fast, precise and efficient installation** on large surfaces.

Features



Warranty



Instant 20 dB reduction



Waterproof and uncoupling



Suitable for all types of finishes



High compressive strength *

Technical data

Weight/m² (gr): 580

Width (m): 2

Length (m): 10

Manufactured from recycled materials

Impact sound reduction up to 20 dB

Technical data

Calculations according to UNE-EN ISO 12354-2: 2018

Reduction in impact sound transmission level ΔL under floating floor:

F (Hz)	ΔL (dB)			F (Hz)	ΔL (dB)		
	S01	S02	S03		S01	S02	S03
100	-4,2	-24,4	-18,4	800	22,9	11,7	17,7
125	-1,3	-20,6	-14,6	1000	25,8	15,6	21,6
160	2,0	-16,3	-10,3	1250	28,7	19,4	25,4
200	4,9	-12,4	-6,4	1600	32,0	23,7	29,7
250	7,8	-8,5	-2,5	2000	34,9	27,6	33,6
315	10,8	-4,5	1,5	2500	37,8	31,5	37,5
400	13,9	-0,4	5,7	3150	40,8	35,5	41,5
500	16,8	3,5	9,5	4000	43,9	39,6	45,7
630	19,8	7,5	13,5	5000	46,9	43,5	49,5

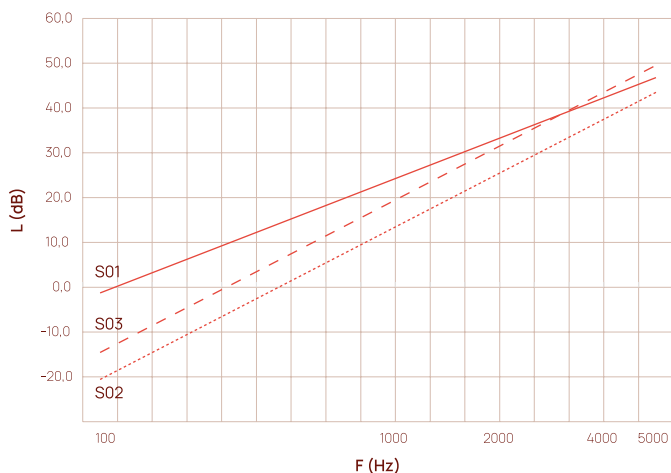

Reduction in impact sound pressure level ΔL as a floating floor system:

S01: Floating screed made of mortar	ΔL_w (dB) 19,8	m' (kg/m ²): 220	f_0 (Hz): 138
S02: Dry floating floor (gypsum board)	ΔL_w (dB) 11,6	m' (kg/m ²): 25	f_0 (Hz): 409
S03: Dry floating floor (wood)	ΔL_w (dB) 11,5	m' (kg/m ²): 50	f_0 (Hz): 289

Reduction in impact sound **19,8 dB**

Product

Ref.	Description	Size
IU70001	Roll G-Sound Premium	2 x 10 m · 20 m ²

Logistics

Units/box	Units/pallet
1	40

Thermo Seal

Heat-weldable
membrane



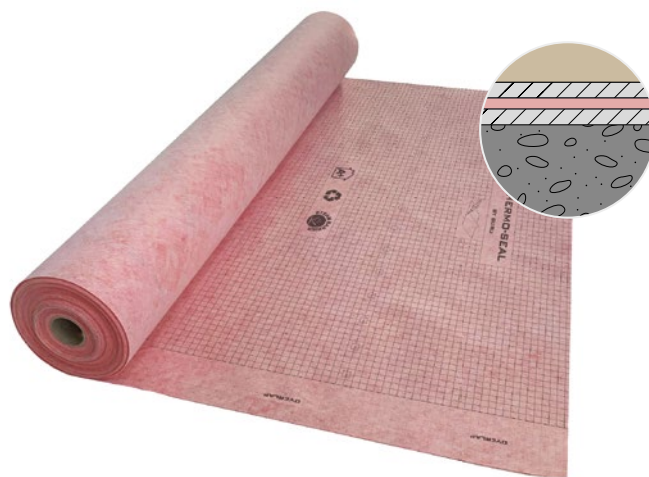

e = 0,65 mm

Thermo Seal is a **waterproof and heat-weldable** geotextile membrane that allows joints to be welded using heat thanks to its **high-polymer-withtent** core, ensuring withtinuous Waterproof without interruptions.

It is composed of several layers: a **Waterproof membrane reinforced with a high-strength plastic film (PP)**, coated on both sides with polyester and polypropylene nonwoven fabric, which provides high durability and versatility.

Features



Warranty



Waterproof

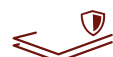

Reinforced with a high-strength layer



Heat-welded overlaps

Technical data

Weight/m² (gr): 340

Thickness (mm): 0,65

Format (m): 1 × 30, 2 × 20 and 1,5 × 20

Product			Logistics	
Ref.	Description	Size	Units/box	Units/pallet
IR52000	Thermo Seal	1 × 30 m	4	100
IR53000	Thermo Seal	2 × 20 m	4	100
IR54000	Thermo Seal	1,5 × 20 m	5	100

W-S Self-Adhesive

Adhesive
membrane



Indoor



Corrugated roof





e = 0,5 mm

W-S Self-Adhesive is an EVA C membrane designed to ensure the waterproofing of flat surfaces **without the need for cementitious adhesive** during installation, thereby reducing installation time and system build-up to a minimum.

Features



Warranty



Waterproof



Multi-layer structure

Technical data

Weight/m² (gr): 315

Thickness (mm): 0,5

Format (m): 1,4 × 20

*The use of W-S Self-Adhesive is recommended for smooth, non-porous surfaces such as metal, plastics, glass, etc.

Product

Ref.	Description	Size
IF54100	W-S Self-Adhesive	1,4 × 20 m

W-S Air

Vapour-permeable
membrane





e = 0,4 mm

W-S Air is a watertight and vapour-permeable membrane designed for vapour control in pitched roofs and ventilated façades. It is installed beneath the protective layer and over the supporting structure, whether laid on beams, boards (concrete, wood, panels) or directly over the thermal insulation.

Features



Warranty



Waterproof



Prevents heat loss caused by convection and condensation



High vapor permeability



Suitable for installation on pitches >5%

Technical data

Weight/m² (gr): 130

Thickness (mm): 0,4

Microporous film

Nonwoven fleece on both sides

Product

Ref.	Description	Size
IH70001	W-S Air	1,5 x 50 m

Logistics

Units/box	Units/pallet
3	40

Installation accessories for Technical Membranes

Reinforcements for critical points

W-S Tub

Pipe collar.
Ø18- Ø 22 mm



W-S Dex

External corner reinforcement 90°.



W-S Din

Internal corner reinforcement. 90°.



NEW PRODUCT

W-S Dex 135°

External corner reinforcement 135°. Includes one left-hand and one right-hand reinforcement.



NEW PRODUCT

W-S Din 135°

Internal corner reinforcement 135°.



Ref.	Description	Format
IG60004	W-S Tub	Bag 2 units
IGU6005	W-S Dex	Bag 2 units
IGU6006	W-S Din	Bag 2 units
IGU6020	W-S Dex 135°	Bag 2 units: 1 left + 1 right
IGU6012	W-S Din 135°	Bag 2 units

NEW

Joining elements

W-S Band 14 / 34

Reinforcement and finishing strip for junctions with vertical upstands and joints.



W-S Self-Adhesive

Water-Stop waterproofing membrane adhesives in patch and tape formats.



Safetub

Adaptable collar for pipes, mixer valves, roof vent stacks, etc.

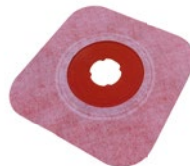

W-S Passtub

Heat-welded pipe sleeve.
* Please consult the possibility of customising the pipe diameter.

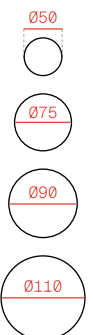
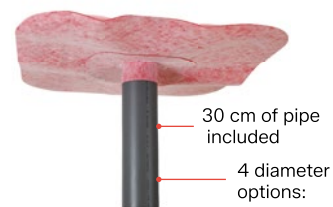

Ref.	Description	Size	Format
IG61000	W-S Band 14	14 cm x 20 m	Roll
IG62000	W-S Band 34	34 cm x 20 m	Roll
IGU6032	W-S Patch Self-Adhesive	10 x 10 cm	Patch
IGU6031	W-S Band Self-Adhesive	12,5 cm x 20 m	Roll
IG60020	Safetub	Ø 32-50	Bag 5 pcs
IG60021	Safetub	Ø 63-75	Bag 5 pcs
IG60022	Safetub	Ø 90-128	Bag 5 pcs
IG56021	W-S Passtub	Ø 50 mm	Bag 1 pc
IG56022	W-S Passtub	Ø 75 mm	Bag 1 pc
IG56023	W-S Passtub	Ø 90 mm	Bag 1 pc
IG56024	W-S Passtub	Ø 110 mm	Bag 1 pc

Accessories for a complete system.

Accessories complete the system and ensure a safer, more precise and more efficient installation, providing withtinuity, compatibility and the required finish for each application.

Adhesives

Easeal

Single-component mortar.
Elastic and flexible waterproofing mortar.



W-S Butil

Double-sided sealing tape
for jointing.



W-S Mastic

High-modulus MS polymer
sealing adhesive.



NEW PRODUCT

W-S Oneseal

Flexible single-component modified
polyurethane adhesive.

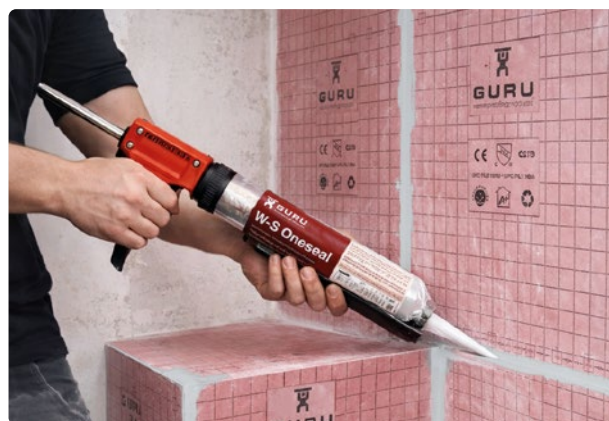

Product

Ref.	Description	Size	Format	Coverage
IG60023	Easeal	20 kg	Bag	Variable *
IG60024	Easeal	3 kg	Bucket	Variable *
IG63000	W-S Butil	5 cm x 10 m	Roll	10 m
IG64000	W-S Mastic	290 ml	Cartridge	6 ml
IG65000	W-S Oneseal	6 kg	Bucket	Variable *
IG65001	W-S Oneseal	600 ml	Sausage pack	Variable *

* Coverage / withsumption for bonding and sealing membrane joints according to joint type:

Overlap of Water-Stop membranes (Easeal)	± 0,07 kg/m	1 kg ≈ 14 m
Water-Stop membranes with W-S Band 14 cover strip (Easeal)	± 0,20 kg/m	1 kg ≈ 5 m
G-Flex membranes with W-S Band 14 strip (Easeal)	± 0,57 kg/m	1 kg ≈ 2 m
Overlap of Water-Stop membranes (Oneseal)	± 0,08 kg/m	1 kg ≈ 13 m
Water-Stop membranes with W-S Band 14 cover strip (Oneseal)	± 0,22 kg/m	1 kg ≈ 5 m
G-Flex membranes with W-S Band 14 strip (Oneseal)	± 0,58 kg/m	1 kg ≈ 2 m

Installation accessories for Technical membranes

Tools

G-Trowel

G-Trowel 3: General-use trowel for Water-Stop membrane. Ideal for mosaics.
 G-Trowel 4,5: General-use trowel for Water-Stop membrane. Ideal for large formats.
 G-Trowel 6: General-use trowel for G-Flex membrane.



W-Spatula

Spatula for expelling excess air during the installation of the Water-Stop membrane.



Ref.	Description	Size	Format
IG67000	G-Trowel	3 × 3 mm (teeth)	1 pc
IG67001	G-Trowel	4,5 × 4,5 mm (teeth)	1 pc
IG67002	G-Trowel	6 × 6 mm (teeth)	1 pc
IG67003	W-Spatula	-	1 pc

Modular linear channel for exterior applications with integrated waterproofing

Raynex Premium

Modular linear drainage system for exterior applications, available with two stainless-steel grate designs: single-slot grate and double-slot grate.



Raynex PVC

Modular linear drainage system for exterior applications with PVC grate.



Ref.	Description	Size
IX45401	Drain channel and grate Raynex premium single-slot with Water-Stop	120 cm
IX45403	Angle 90° Grate integra premium single-slot with Water-Stop	-
IX45404	Access cover for Raynex Premium integrated single-slot grate	-
IX45301	Drain channel and grate Raynex premium double-slotwith Water-Stop	120 cm
IX45303	Angle 90° Grate integra premium double-slotwith Water-Stop	-
IX45121	Drain channel and grate Raynex PVC double-slotwith Water-Stop	120 cm
IX45201	Drain channel and grate Raynex PVC double-slotwith Water-Stop	200 cm *
IX10005	Angle 90° Raynex PVC with Water-Stop	-

* For more information about Raynex Premium, Raynex PVC and their accessories, see the Drainage Systems catalogue (pages 78-81). ►



Drainage Systems

01 Corporate Brochure

02 Technical Membranes

03 Drainage Systems

04 Modular Systems

Efficiency and elegance thanks to integrated waterproofing, enabling optimum drainage without affecting the aesthetics of the surroundings or the performance of the finish.



WATER-STOP
4 LAYER SUPERIOR TECHNOLOGY

proofing products®
RU

Product Index

Thanks to the innovative approach that characterizes GURU, we have developed and manufactured a range of advanced **drainage systems** for both outdoor and indoor applications.

Our products combine elegance and efficiency, creating systems with **integrated waterproofing** and exclusive technologies to improve drainage.

Outdoor drainage systems

Raynex Premium P 78-79

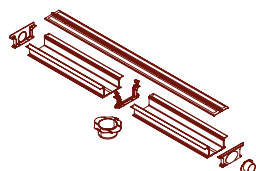

Raynex PVC P 80-81

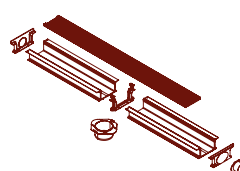

W-S Kit Terrace / W-S Kit Terrace Plus P 82-83

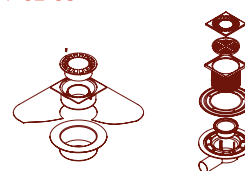

Shower systems

Drain Tryphon P 86-87

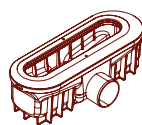

Drain Ruber P 88-89

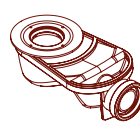

Revolux Tryphon Kit P 90-93

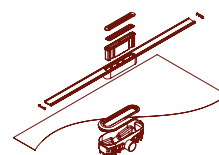

Revolux Ruber Kit P 94-95

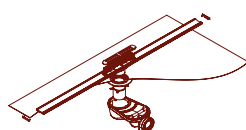

Evolux Tryphon Kit P 96-103

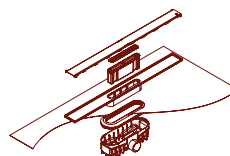

Evolux Integra Tryphon Kit P 104-105

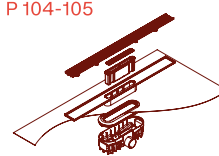

Evolux Ruber Kit Lineal P 106-113

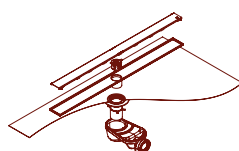

Evolux Vinyl P 114-115

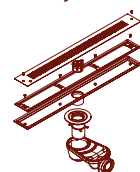

Evolux Ruber Kit Puntual P 116-117

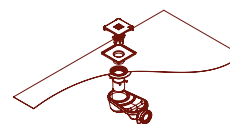

System Evo P 118-119

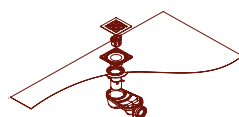

W-S Bathkit / W-S Bath P 120-123

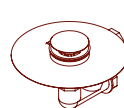

SafeBand P 124-127



Shelf P 128-131

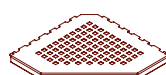

Installation Profiles P 132

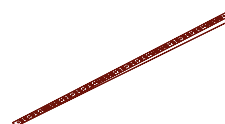

Accessories and spare parts P 133-135

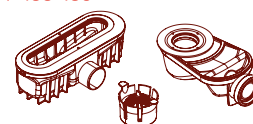

Custom Kit (Tryphon Base Kit) P 138-141

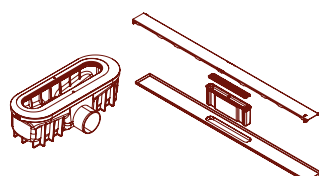

Custom Kit (Ruber Base Kit) P 142-145

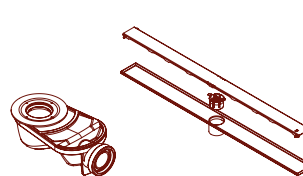

DRAINAGE SYSTEMS

Outdoor drainage systems







With single-slot grate



With double-slot grate

Product			Logistics	
Ref.	Description	Measure	Units/Box	Units/Pallet
IX45300	Channel and grate Raynex premium with double-slot grate	120 cm	8	72
IX45301	Channel and grate Raynex premium with double-slot grate with Water-Stop	120 cm	6	54
IX45400	Channel and grate Raynex premium with single-slot grate	120 cm	8	72
IX45401	Channel and grate Raynex premium with single-slot grate	120 cm	6	54

Installation components

Product			Logistics	
Ref.	Description	Measure	Units/Box	Units/Pallet
IX45302	Corner 90° Grate integra premium with double-slot grate	-	200	-
IX45303	Corner 90° Grate integra premium with double-slot grate with Water-Stop	-	200	-
IX45402	Corner 90° Grate integra premium with single-slot grate	-	200	-
IX45403	Corner 90° Grate integra premium with single-slot grate	-	200	-
IX45404	Access cover for Grate integra premium with single-slot grate	-	4	108

Raynex Premium is a modular linear drainage system for outdoor applications, available with **two stainless steel grate designs** and the option of incorporating integrated **waterproofing**.

With single-slot grate

The single-slot grate is ideal for projects seeking to reduce visual impact without compromising drainage capacity.

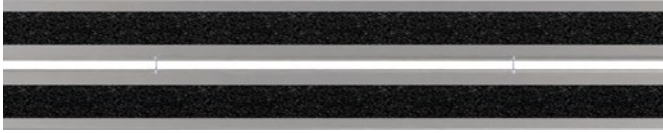

With double-slot grate

The double-slot grate allows a fully accessible installation, facilitating channel cleaning while maintaining perfect integration with the surroundings.



Features

- Tile-in grate manufactured in stainless steel
- Two grate models
- Site-adaptable
- UV-resistant material for outdoor exposure.
- Lightweight yet resistant material, A15 certified
- High drainage capacity.
- Low-thickness waterproofing integrated into the channel.
- Suitable for light traffic up to 1,500 kg.
- Joints bonded with PVC adhesive.

Technical data

- EN1433
- Class A15 for light traffic
- Open area: 6000 mm²/metre

Installation height

With grate de with single-slot grate With grate de with double-slot grate

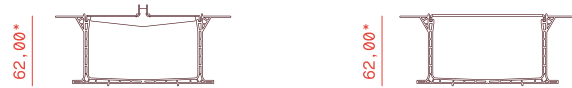

*Installation height excluding floor finish thickness

Components



- 1a. Floor finish (width not defined) / 1b. Floor finish (width: 76 mm)
- 2a. Single-slot grate / 2b. Double-slot grate / 3. Channel / 4. End cap
- 5. Connector / 6a. Ø90 water outlet / 6b. Ø50 water outlet / 7. Rivets
- 8. WATER-STOP overlap (optional) WATER-STOP (opcional)

Measures (mm)

2a. with single-slot grate

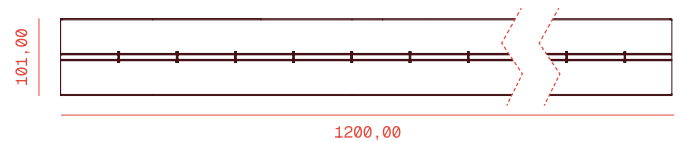

2b. with double-slot grate

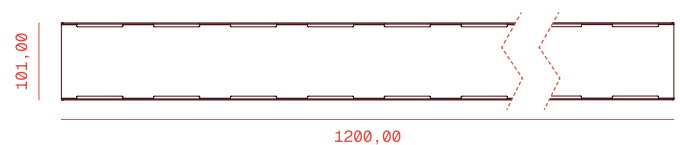

Tile-in access cover in single-slot RAYNEX PREMIUM:

Optionally, it can incorporate a tile-in access cover that allows easy access for cleaning and maintenance tasks.

Measures (mm)

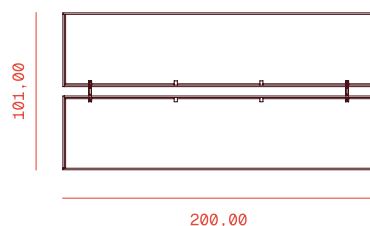

*Anti-slip tape included

Raynex

Modular linear channel drain for outdoor applications

PVC



Channel and grate RAYNEX double-slot with waterproofing.

Product			Logistics	
Ref.	Description	Measure	Units/Box	Units/Pallet
IX45120	Channel and grate Raynex PVC double-slot	120 cm	8	96
IX45121	Channel and grate Raynex PVC double-slot with Water-Stop	120 cm	6	54
IX45200	Channel and grate Raynex PVC double-slot	200 cm *	8	100
IX45201	Channel and grate Raynex PVC double-slot with Water-Stop	200 cm *	8	100

Following the same line as Raynex Premium, we present a more competitive version with a PVC grate and also with the option of **integrated waterproofing**.

Its compact and lightweight design, together with a solid structure, is capable of withstanding light traffic of up to 1,500 kg.

In addition, its integrated paving option makes it an elegant and discreet channel drain.

Features	Tile-in grate, 100% removable for cleaning.	Lightweight yet resistant material, A15 certified.	Suitable for light traffic up to 1,500 kg.
	Site-adaptable.	High drainage capacity.	Joints bonded with PVC adhesive.
	UV-resistant material for outdoor exposure.	Low-thickness waterproofing integrated into the channel.	

Technical data	EN1433
	Class A15 for light traffic
	Open area: 6000 mm ² /metre

Installation height

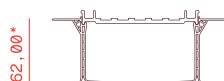

*Installation height excluding floor finish thickness

Components

- 1. Floor finish (width: 76 mm) / 2. Grate / 3. Channel / 4. End cap
- 5. Connector / 6a. Ø90 water outlet / 6b. Ø50 water outlet / 7. Rivets
- 8. WATER-STOP overlap (optional) / 9. 90° corner

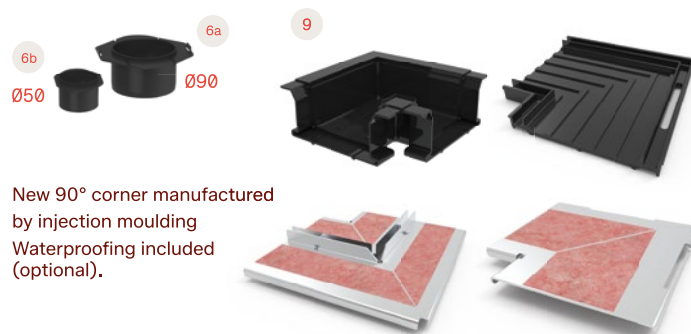

New 90° corner manufactured by injection moulding
Waterproofing included (optional).

Measures (mm)

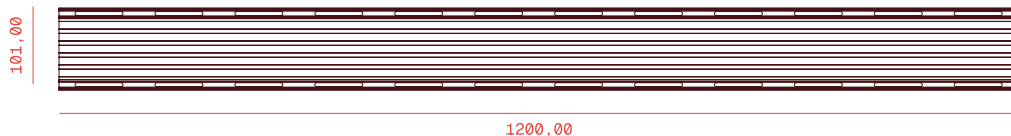

Product			Logistics	
Ref.	Description	Measure	Units/Box	Units/Pallet
IX10000	Connector	-	200	-
IX10001	End cap	-	200	-
IX10002	Pipe Diameter Ø50 mm	-	25	3500
IX10004	Pipe Diameter Ø90 mm	-	3	420
IX10003	Corner 90° Raynex PVC	-	4	108
IX10005	Corner 90° Raynex PVC with Water-Stop	-	4	108

* For 200 cm channel and grate. MINIMUM ORDER OF 8 units. ** For large projects, the channel length can be customized up to 3 metres..

Kit Terrace Outdoor drain

The Terrace Kit is a **complete solution for waterproofing terraces and balconies**. It consists of a PVC flange heat-welded to the waterproofing membrane, ensuring a watertight connection, a 25 mm trapped drain, two outlet options (vertical or horizontal), and a PVC grate.



Measures (mm)

Vertical outlet

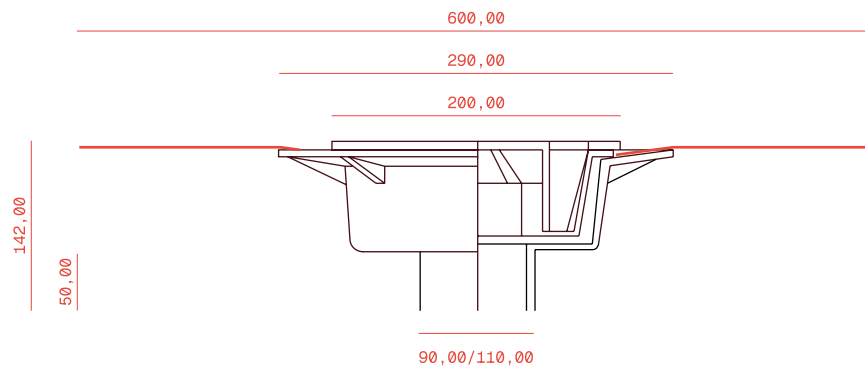

Horizontal outlet

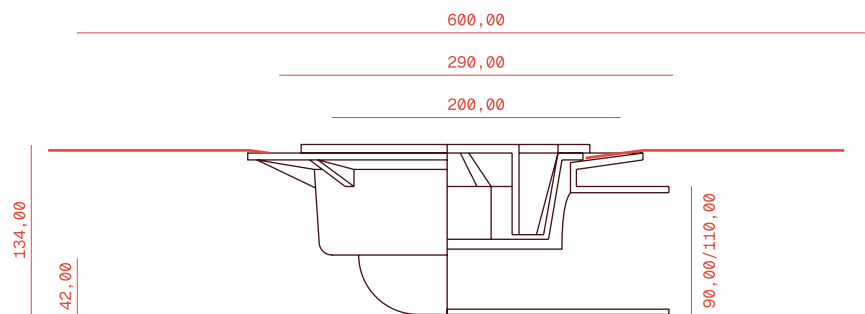

Product			Logistics
Ref.	Description	Outlet	Units/Box
IE46000	Kit Terrace V90	Vertical Dn/De 90	6
IE46001	Kit Terrace V110	Vertical Dn/De 110	6
IE46002	Kit Terrace H90	Horizontal Dn/De 90	6
IE46003	Kit Terrace H110	Horizontal Dn/De 110	6

Kit Terrace

Outdoor drain

PLUS

Like the Terrace Kit, the Plus version offers a complete waterproofing solution for outdoor applications with quick and safe installation. In addition, its manufacture with high-quality materials guarantees resistance to corrosion, weather exposure and temperature changes, offering an excellent balance between quality, durability and price.



Measures (mm)

Vertical outlet

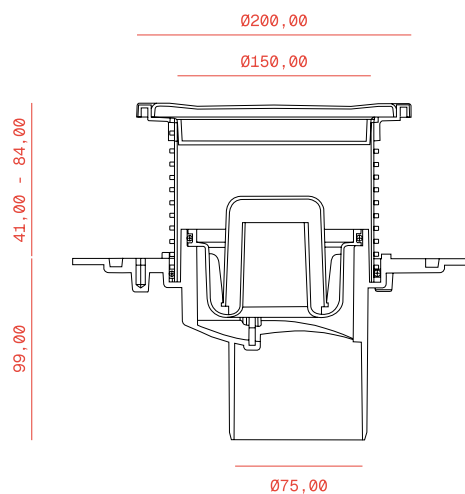

Horizontal outlet

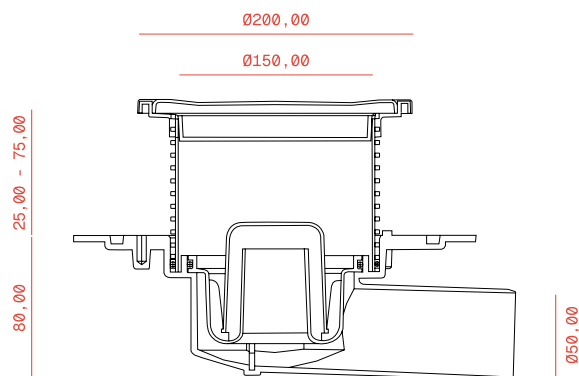

Product					Logistics	
Ref.	Description	Outlet	Flow rate (l/min)		Units/Box	
			W.T.*	D.T.*		
IE46007	Kit Terrace Plus V75	Vertical outlet DN/DE 75	45	100	6	
IE46008	Kit Terrace Plus H50	Horizontal outlet DN/DE 50	45	100	6	

*W.T.: Water Trap | D.T.: Dry Trap

DRAINAGE SYSTEMS

Shower systems





GURU
waterproofing products

WATER-STOP
A WATER BARRIER TECHNOLOGY



CE CSTB
GPC FILE 0900-U

GURU
waterproofing products

GURU
waterproofing products

CE
GPC FILE 0900-U

GURU
waterproofing products

GURU
waterproofing products

Tryphon Drain

TRYPHON, a drain with a removable trap to facilitate maintenance, self-cleaning, and with a drainage flow rate of up to 32 l/min.

This drainage system adapts to any installation thanks to its two trap options (dry or Water Trap), a collector adjustable up to 35 mm in height, and three outlet options: horizontal, low-height horizontal and vertical, the latter being uncommon on the market.

It allows flush floor installation for complete integration and features a factory heat-sealed waterproofing membrane that ensures long-lasting protection.

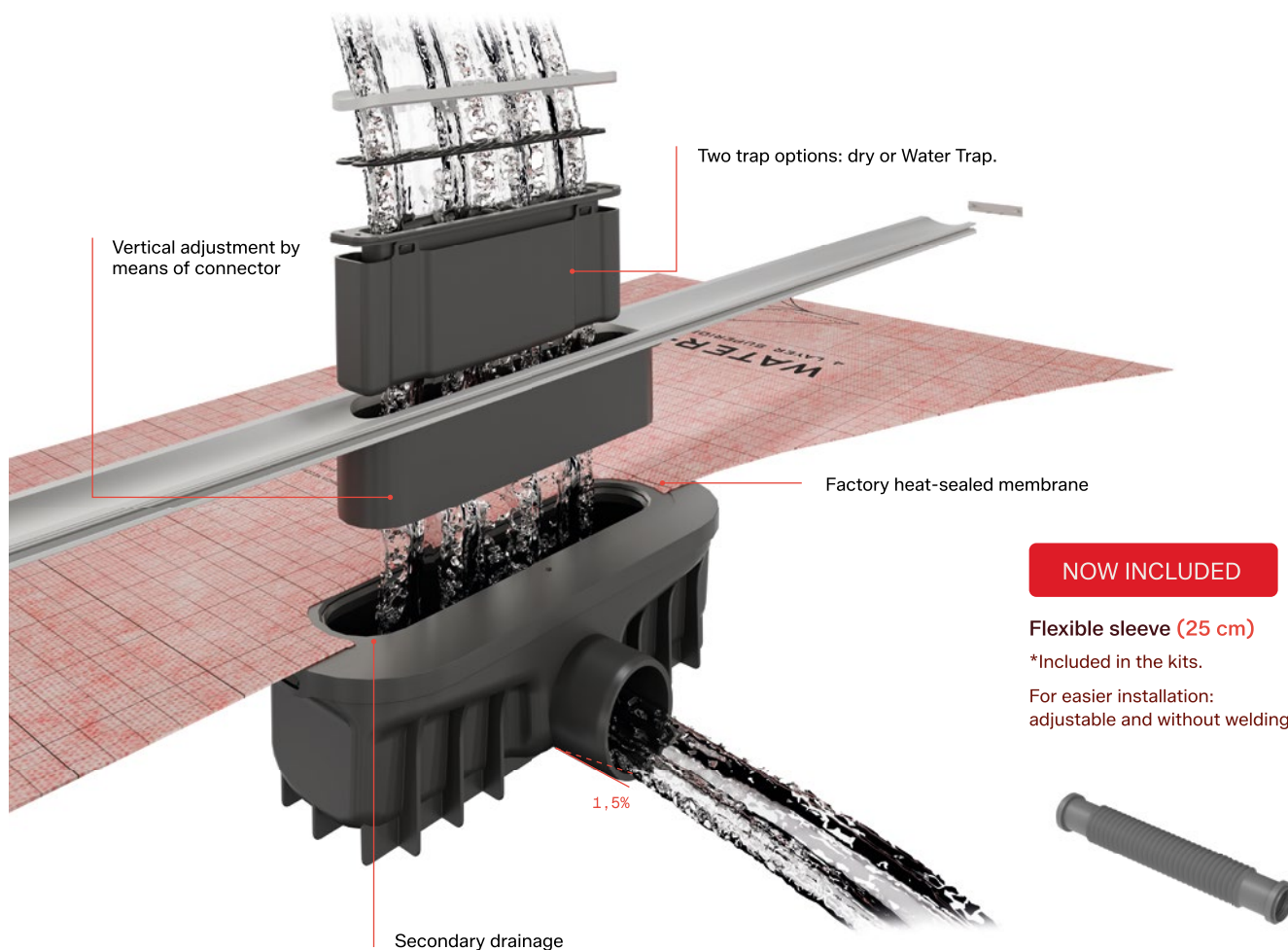

Drainage flow rate
Up to **32 l/min**

Heat-sealed membrane dimensions (cm)

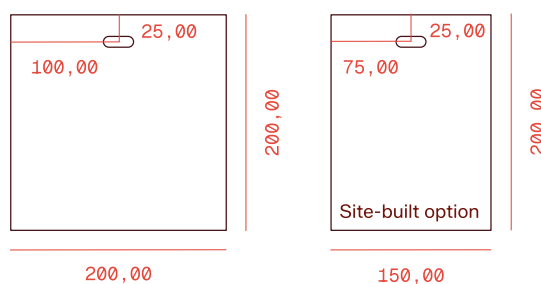

Tryphon

Features

Frontal outlet
 Outlet DN/DE 50 mm
 Water Trap 50 mm + Dry trap

Components

1. Protective cap
 2. Water Trap / Dry trap
 3. Body Tryphon



Measures (mm)

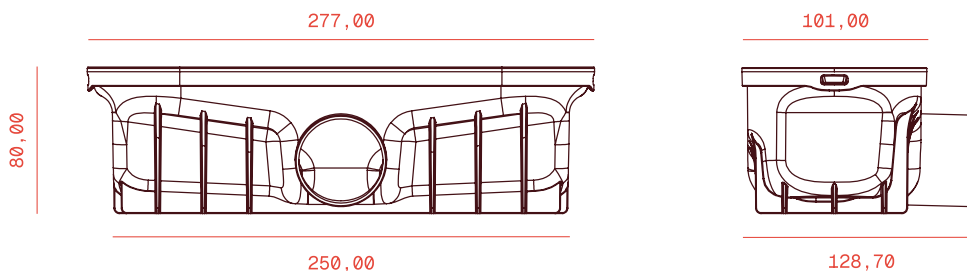

Tryphon Reduced

Features

Low-height horizontal outlet
 Outlet DN/DE 40 mm
 Dry trap

Components

1. Protective cap
 2. Dry trap
 3. Tryphon Reduced body



Measures (mm)

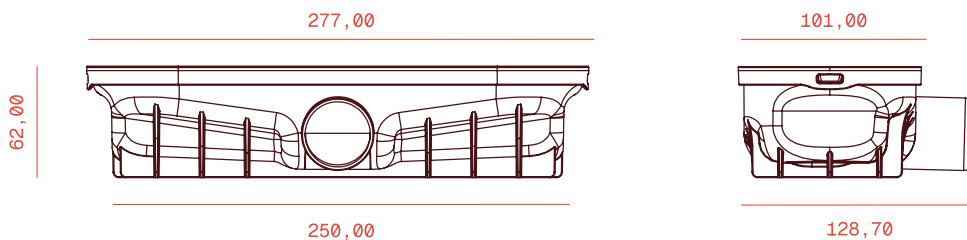

Tryphon Vertical

Features

Vertical outlet
 Outlet DN/DE 50 mm
 Water Trap 50 mm + Dry trap

Components

1. Protective cap
 2. Water Trap / Dry trap
 3. Tryphon Vertical body



Measures (mm)

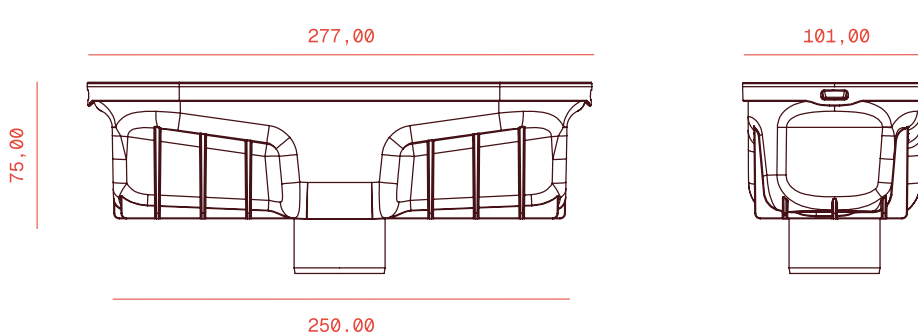

Ref.

Description

IG60036	Body Tryphon
IG60031	Tryphon Reduced body
IG60032	Tryphon Vertical body

Ruber Drain

RUBER is an **adjustable and self-cleaning** drain with a drainage flow rate of up to 36 l/min. To adapt to the needs of each installation, it is available in two heights: one with a 50 mm trap and another with a 28 mm trap, both removable if required. In addition, it does not require adhesive bonding, since installation is carried out by means of a push-fit seal.

It includes a factory heat-bonded membrane, ensuring safe and durable **waterproofing**.

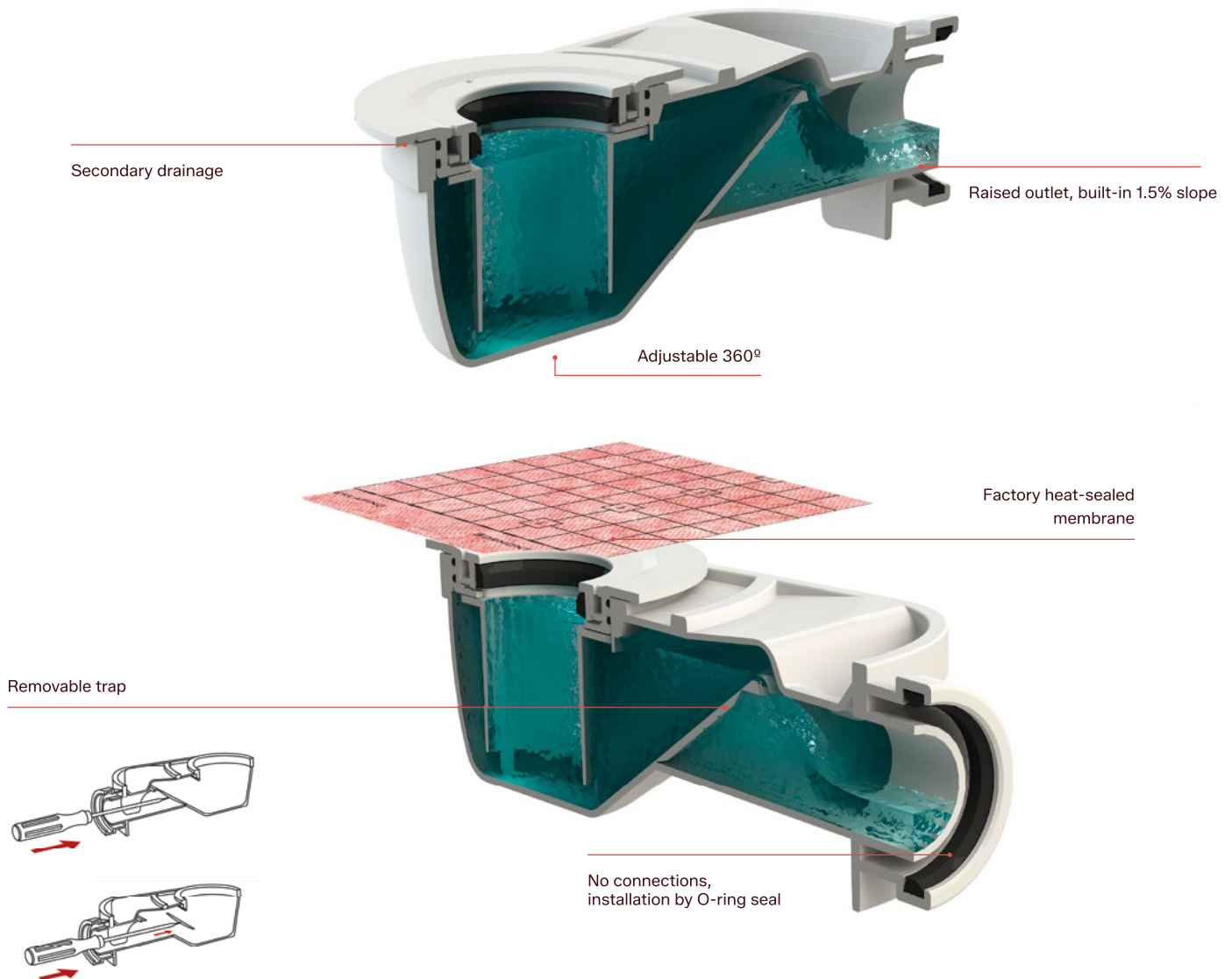

Drainage flow rate
Up to **36 l/min**

Heat-sealed membrane dimensions (cm)

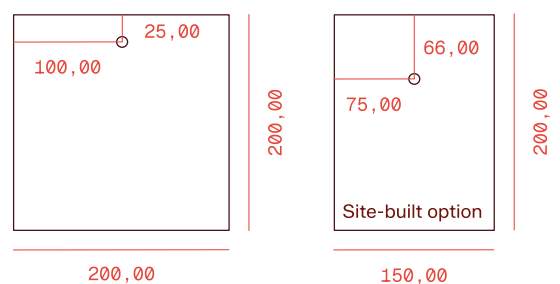

Ruber H50

Features

Horizontal outlet
 Outlet DN/DI 50 mm
 Trap 50 mm
 Total installation height including 1 cm floor finish: 90 mm
 Bonded connection

Components

1. Ruber collar
2. Body
3. O-ring



Measures (mm)

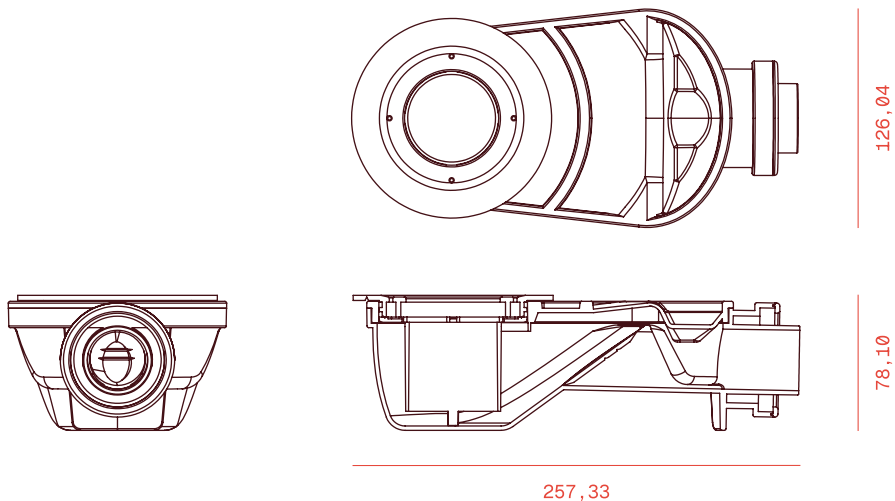

Ruber H28

Features

Horizontal outlet
 Outlet DN/DI 40 mm
 Trap 28 mm
 Total installation height including 1 cm floor finish: 70 mm
 Bonded connection

Components

1. Ruber collar
 2. Body
 3. Ø40 sliding sleeve
- *Included in the kits.

NOW INCLUDED



Measures (mm)

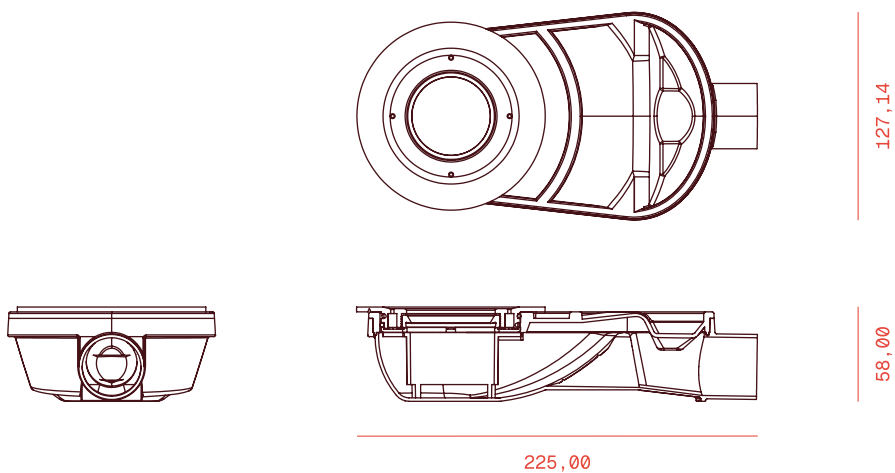

Ref.

Description

IG60035 Drain Ruber H50

IG60030 Drain Ruber H28

Revolux Kit

Complete
cut-to-size shower kit



Revolux is a shower system with a cut-to-size grate to adapt to any shower size and shape. It stands out for its two drainage options and its high drainage flow rate, ensuring highly efficient water management.

It offers five colours and two designs to integrate with the aesthetics of any bathroom. Manufactured in 6063-T6 aluminium, it guarantees durability and corrosion resistance.

Measure, cut and install.

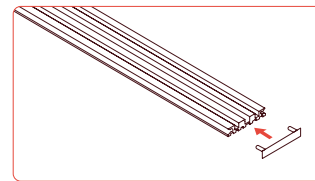
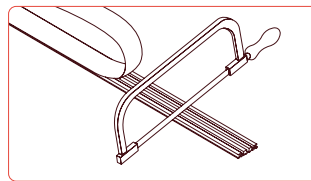

Features

- Can be cut to the required size
- 2 sizes: 1 and 2 metres long
- We offer 2 models with 5 finishes each
- Removable trim
- Grooved with lower dovetail for improved grip to the substrate with C2 tile adhesive
- Fast installation
- Standard EN1253 / DIN18534

Technical data

- Load class K3
- Grate height: 8 mm
- Aluminium 6063 architectural grade
- Anodizing: 25 micras
- Vertical grate adjustment

System contents

Revolux Tryphon Kit



1. Trim / 2. Hair strainer / 3. Trap / 4. Revolux grate
5. Connection collector / 6. End cap / 7. Water-Stop membrane
8. Heat-sealed adapter / 9. Tryphon body / 10. Flexible Pushfit sleeve

Revolux Ruber Kit

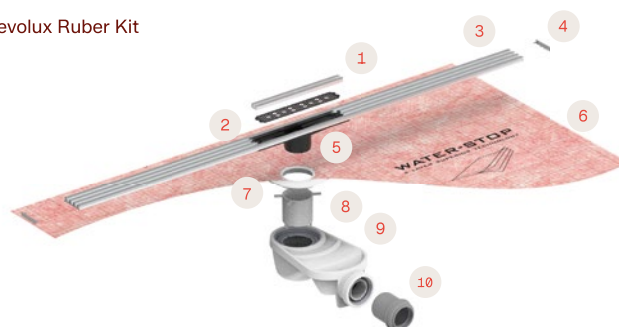

1. Trim / 2. Hair strainer / 3. Revolux grate / 4. End cap
5. Connection collector / 6. Water-Stop membrane / 7. Heat-sealed adapter
8. Ruber collar / 9. Ruber drain / 10. Ø50/40 reducer

Models

Revolux Cavity Chrome



Revolux Cavity Gold



Revolux Cavity Rose



Revolux Cavity Black



Revolux Cavity Nickel



Revolux Curve Chrome



Revolux Curve Gold



Revolux Curve Rose



Revolux Curve Black



Revolux Curve Chrome



Complete cut-to-size shower kit **Revolux Tryphon Kit**

Revolux Curve



Product								Logistics			
Finish	Tryphon			Tryphon Reduced		Model	Measure	Membrane W-S	Units/ Box	Units/ Pallet	
	Ref.	Flow rate (l/min)		Ref.	Flow rate (l/min)						
		W.T.*	D.T.*		W.T.*						D.T.*
	IT23004	32	49	IT23004R	49	Curve Chrome	100 cm	2 X 2 · 4 m ²	6	40	
	IT63004	32	49	IT63004R	49	Curve Gold	100 cm	2 X 2 · 4 m ²	6	40	
	IT83004	32	49	IT83004R	49	Curve Rose	100 cm	2 X 2 · 4 m ²	6	40	
	IT53004	32	49	IT53004R	49	Curve Black	100 cm	2 X 2 · 4 m ²	6	40	
	IT93004	32	49	IT93004R	49	Curve Nickel	100 cm	2 X 2 · 4 m ²	6	40	
	IT23200	32	49	IT23200R	49	Curve Chrome	200 cm	2,5 X 2 · 5 m ²	3	32	
	IT63200	32	49	IT63200R	49	Curve Gold	200 cm	2,5 X 2 · 5 m ²	3	32	
	IT83200	32	49	IT83200R	49	Curve Rose	200 cm	2,5 X 2 · 5 m ²	3	32	
	IT53200	32	49	IT53200R	49	Curve Black	200 cm	2,5 X 2 · 5 m ²	3	32	
	IT93200	32	49	IT93200R	49	Curve Nickel	200 cm	2,5 X 2 · 5 m ²	3	32	

*W.T.: Water Trap | D.T.: Dry Trap

Revolux Cavity



Product								Logistics			
Finish	Tryphon			Tryphon Reduced		Model	Measure	Membrane W-S	Units/ Box	Units/ Pallet	
	Ref.	Flow rate (l/min)		Ref.	Flow rate (l/min)						
		W.T.*	D.T.*		W.T.*						D.T.*
	IT24004	32	49	IT24004R	49	Cavity Chrome	100 cm	2 X 2 · 4 m ²	6	40	
	IT64004	32	49	IT64004R	49	Cavity Gold	100 cm	2 X 2 · 4 m ²	6	40	
	IT84004	32	49	IT84004R	49	Cavity Rose	100 cm	2 X 2 · 4 m ²	6	40	
	IT54004	32	49	IT54004R	49	Cavity Black	100 cm	2 X 2 · 4 m ²	6	40	
	IT94004	32	49	IT94004R	49	Cavity Nickel	100 cm	2 X 2 · 4 m ²	6	40	
	IT24200	32	49	IT24200R	49	Cavity Chrome	200 cm	2,5 X 2 · 5 m ²	3	32	
	IT64200	32	49	IT64200R	49	Cavity Gold	200 cm	2,5 X 2 · 5 m ²	3	32	
	IT84200	32	49	IT84200R	49	Cavity Rose	200 cm	2,5 X 2 · 5 m ²	3	32	
	IT54200	32	49	IT54200R	49	Cavity Black	200 cm	2,5 X 2 · 5 m ²	3	32	
	IT94200	32	49	IT94200R	49	Cavity Nickel	200 cm	2,5 X 2 · 5 m ²	3	32	

*W.T.: Water Trap | D.T.: Dry Trap

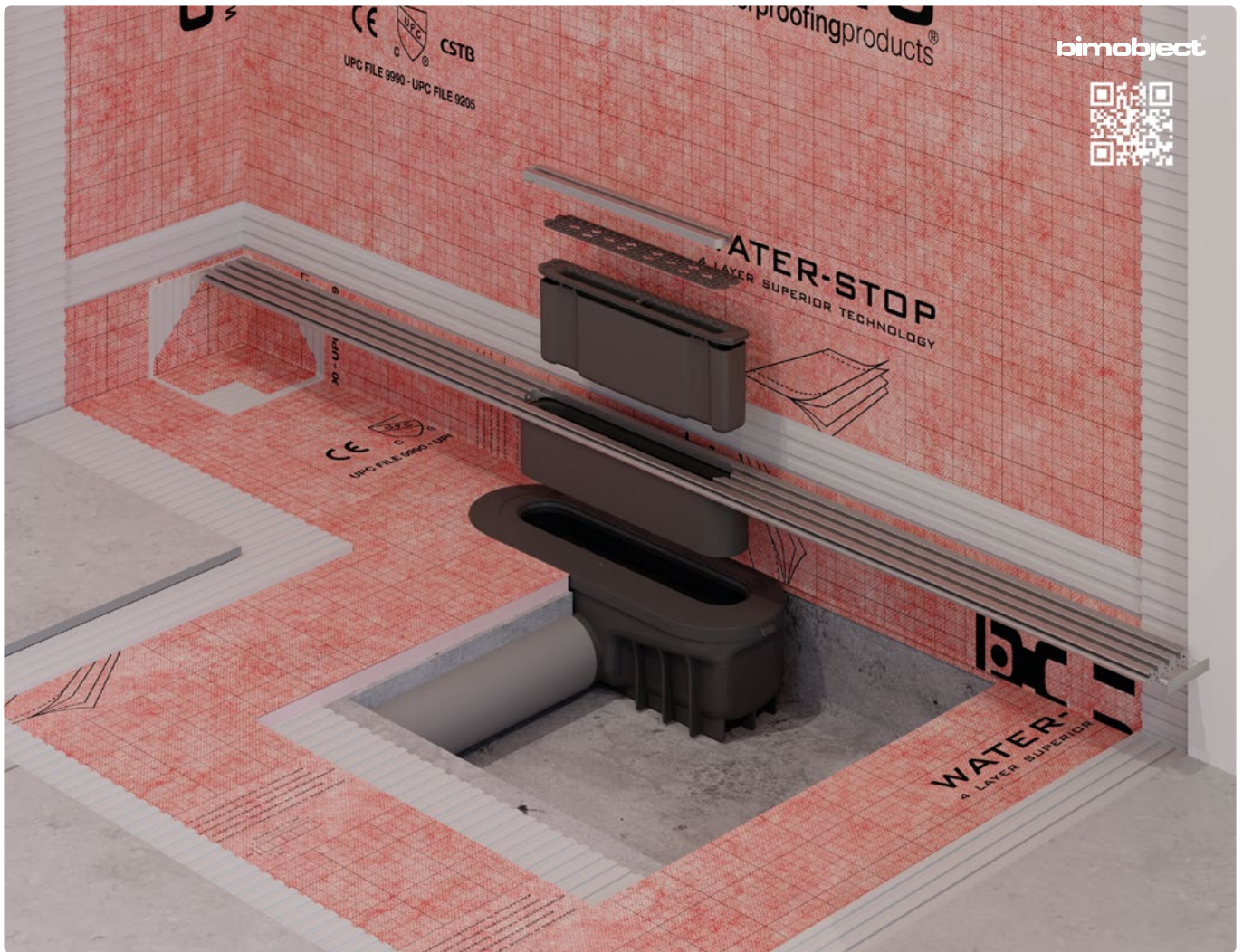

System contents

Drain to be selected 1

Option 1
Drain Tryphon



Option 2
Drain Tryphon Reduced



Complementary accessory
Tryphon Vertical body
*See more on page 87 (IG60032) ▶



System contents



1. Drain to be selected / 2. Revolux grate, trim, end caps and hair strainer (selected model and size) / 3. Hook for lifting grates
4. Mortar level cap / 5. W-S Din x2 / 6. W-S Tub x2 / 7. Flexible Pushfit sleeve
8. Water-Stop membrane with heat-sealed adapter (2 x 2 or 2,5 x 2 m) / 9. Revolux Tryphon Kit box

Installation height

Including a 1 cm floor finish thickness.

Tryphon

88,00

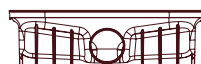

Tryphon Reduced

70,00



Tryphon Vertical

83,00

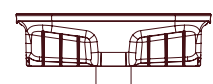

Complete cut-to-size shower kit **Revolux Ruber Kit**

Revolux Curve



Product							Logistics	
Finish	Ruber H50	Ruber H28	Flow rate (l/min)	Model	Measure	Membrane	Units/Box	Units/Pallet
	IE23004	IE23004R	28	Curve Chrome	100 cm	2 X 2 · 4 m ²	6	40
	IE63004	IE63004R	28	Curve Gold	100 cm	2 X 2 · 4 m ²	6	40
	IE83004	IE83004R	28	Curve Rose	100 cm	2 X 2 · 4 m ²	6	40
	IE53004	IE53004R	28	Curve Black	100 cm	2 X 2 · 4 m ²	6	40
	IE93004	IE93004R	28	Curve Nickel	100 cm	2 X 2 · 4 m ²	6	40
	IE23200	IE23200R	28	Curve Chrome	200 cm	2,5 X 2 · 5 m ²	3	32
	IE63200	IE63200R	28	Curve Gold	200 cm	2,5 X 2 · 5 m ²	3	32
	IE83200	IE83200R	28	Curve Rose	200 cm	2,5 X 2 · 5 m ²	3	32
	IE53200	IE53200R	28	Curve Black	200 cm	2,5 X 2 · 5 m ²	3	32
	IE93200	IE93200R	28	Curve Nickel	200 cm	2,5 X 2 · 5 m ²	3	32

Revolux Cavity



Product							Logistics	
Finish	Ruber H50	Ruber H28	Flow rate (l/min)	Model	Measure	Membrane	Units/Box	Units/Pallet
	IE24004	IE24004R	29	Curve Chrome	100 cm	2 X 2 · 4 m ²	6	40
	IE64004	IE64004R	29	Curve Gold	100 cm	2 X 2 · 4 m ²	6	40
	IE84004	IE84004R	29	Curve Rose	100 cm	2 X 2 · 4 m ²	6	40
	IE54004	IE54004R	29	Curve Black	100 cm	2 X 2 · 4 m ²	6	40
	IE94004	IE94004R	29	Curve Nickel	100 cm	2 X 2 · 4 m ²	6	40
	IE24200	IE24200R	29	Curve Chrome	200 cm	2,5 X 2 · 5 m ²	3	32
	IE64200	IE64200R	29	Curve Gold	200 cm	2,5 X 2 · 5 m ²	3	32
	IE84200	IE84200R	29	Curve Rose	200 cm	2,5 X 2 · 5 m ²	3	32
	IE54200	IE54200R	29	Curve Black	200 cm	2,5 X 2 · 5 m ²	3	32
	IE94200	IE94200R	29	Curve Nickel	200 cm	2,5 X 2 · 5 m ²	3	32

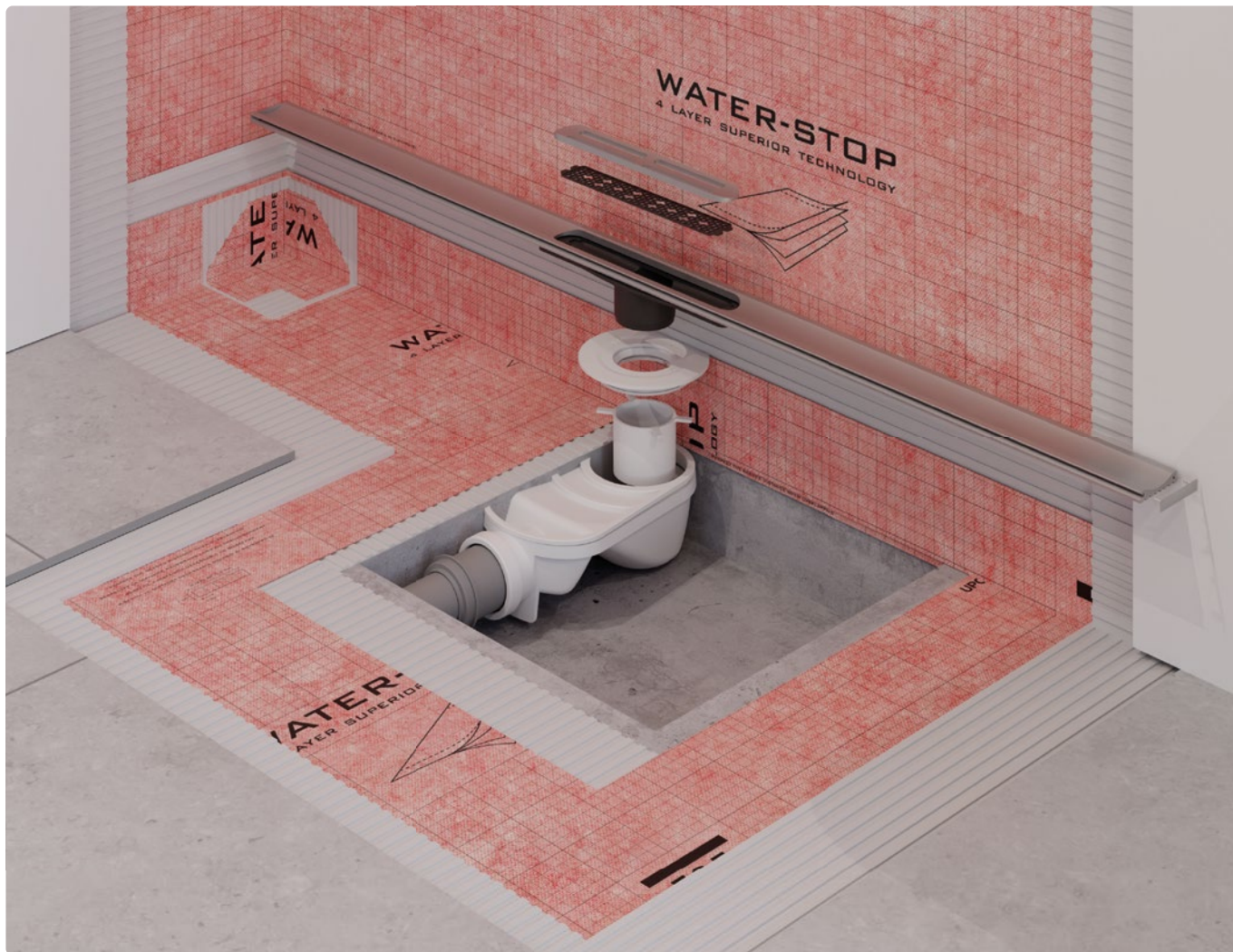

System contents

Drain to be selected

1

Option 1
Drain Ruber H50



Option 2
Drain Ruber H28

NOW INCLUDED



System contents



1. Drain to be selected / 2. REVOLUX grate, trim, end caps and hair strainer (model and size to be selected) / 3. Hook for lifting grates
4. Mortar levelling cap / 5. W-S Din x2 / 6. W-S Tub x2 / 7. Water-Stop membrane with heat-sealed adapter (2 x 2 or 2.5 x 2 m)
8. Revolux Ruber Kit box

Installation height

Including a 1 cm floor finish thickness.

Ruber H50

90,00

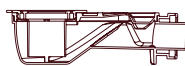

Ruber H28

70,00

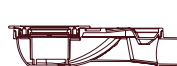

Evolux Kit

Complete shower kit





bimobject
Evolux Tryphon Kit

The Evolux shower system offers a **complete solution for drainage and waterproofing of built-in shower trays.**



bimobject
Evolux Ruber Kit

This set consists of a stainless steel channel and grate, a low-profile trapped drain, and a WATER-STOP waterproof membrane factory-bonded and sealed to a special adapter for connection to the drain.

Features

- Stainless steel structure
- High load resistance
- Waterproofing included
- High drainage capacity
- Wide range of models
- Easy installation
- Effective cleaning
- 10-year warranty

Technical data

- Stainless steel
- PVD and textured finishes

System contents

Evolux Tryphon Kit



1. Evolux grate / 2. Hair strainer / 3. Trap / 4. Channel /
5. Connection collector / 6. Water-Stop membrane / 7. Heat-sealed adapter
8. Tryphon body / 9. Flexible Pushfit sleeve

Evolux Ruber Kit



1. Evolux grate / 2. Hair strainer / 3. Channel / 4. Water-Stop membrane /
5. Heat-sealed adapter / 6. Ruber collar / 7. Ruber drain / 8. Ø50/40 reducer

Models

Evolux Lisa



Evolux Lisa Anti-vandal



Evolux Lisa Gold



Evolux Lisa Dark



Evolux Plus



Evolux Integra (Tryphon)



Evolux Integra (Ruber)



Evolux Microcement



Complete shower kit Evolux Tryphon Kit

Evolux Lisa



Product

Logistics

Finish	Tryphon			Tryphon Reduced			Measure	Membrane W-S	Units/ Box	Units/ Pallet	
	Ref.	Flow rate (l/min)		Ref.	Flow rate (l/min)						
		W.T.*	D.T.*		D.T.*						
●	IT41040	33	47	IT41040R	47		Lisa	40 cm	2 x 2 · 4 m ²	6	40
●	IT41050	33	47	IT41050R	47		Lisa	50 cm	2 x 2 · 4 m ²	6	40
●	IT41000	33	47	IT41000R	47		Lisa	60 cm	2 x 2 · 4 m ²	6	40
●	IT41001	33	47	IT41001R	47		Lisa	70 cm	2 x 2 · 4 m ²	6	40
●	IT41002	33	47	IT41002R	47		Lisa	80 cm	2 x 2 · 4 m ²	6	40
●	IT41003	33	47	IT41003R	47		Lisa	90 cm	2 x 2 · 4 m ²	6	40
●	IT41004	33	47	IT41004R	47		Lisa	100 cm	2 x 2 · 4 m ²	6	40
●	IT41005	33	47	IT41005R	47		Lisa	120 cm	2 x 2 · 4 m ²	3	32
●	IT41150	33	47	IT41150R	47		Lisa	150 cm	2 x 2 · 4 m ²	3	32
●	IT41180	33	47	IT41180R	47		Lisa	180 cm	2 x 2 · 4 m ²	3	32

*W.T.: Water Trap | D.T.: Dry Trap

System contents

Drain to be selected

1

Option 1
Drain Tryphon



Option 2
Drain Tryphon Reduced



Complementary accessory

Tryphon Vertical body

*See more on page 87 (IG60032)



System contents



1. Drain to be selected / 2. Evolux Lisa grate and channel (selected size) and hair strainer / 3. Hook for lifting grates / 4. Mortar level cap
5. W-S Din x2 / 6. W-S Tub x2 / 7. Flexible Pushfit sleeve / 8. Water-Stop membrane with heat-sealed adapter (2 x 2 m) / 9. Evolux Tryphon Kit box

Installation height

Including a 1 cm floor finish thickness.

Tryphon

93,00



Tryphon Reduced

74,00



Tryphon Vertical

88,00

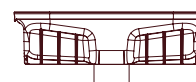

Complete shower kit Evolux Tryphon Kit

Evolux Plus



Product

Logistics

Finish	Tryphon				Tryphon Reduced		Measure	Membrane W-S	Units/ Box	Units/ Pallet
	Ref.	Flow rate (l/min)		Ref.	Flow rate (l/min)					
		W.T.*	D.T.*		D.T.*					
●	IT42000	34	49	IT42000R	49	Plus	60 cm	2 x 2 · 4 m ²	6	40
●	IT42001	34	49	IT42001R	49	Plus	70 cm	2 x 2 · 4 m ²	6	40
●	IT42002	34	49	IT42002R	49	Plus	80 cm	2 x 2 · 4 m ²	6	40
●	IT42003	34	49	IT42003R	49	Plus	90 cm	2 x 2 · 4 m ²	6	40
●	IT42004	34	49	IT42004R	49	Plus	100 cm	2 x 2 · 4 m ²	6	40
●	IT42005	34	49	IT42005R	49	Plus	120 cm	2 x 2 · 4 m ²	3	32
●	IT42150	34	49	IT42150R	49	Plus	150 cm	2 x 2 · 4 m ²	3	32
●	IT42180	34	49	IT42180R	49	Plus	180 cm	2 x 2 · 4 m ²	3	32

*W.T.: Water Trap | D.T.: Dry Trap

System contents

Drain to be selected

1

Option 1
Drain Tryphon



Option 2
Drain Tryphon Reduced



Complementary accessory

Tryphon Vertical body

*See more on page 87 (IG60032) ▶



System contents



1. Drain to be selected / 2. Evolux Plus grate and channel (selected size) and hair strainer / 3. Hook for lifting grates / 4. Mortar level cap
5. W-S Din x2 / 6. W-S Tub x2 / 7. Flexible Pushfit sleeve / 8. Water-Stop membrane with heat-sealed adapter (2 x 2 m) / 9. Evolux Tryphon Kit box

Installation height

Including a 1 cm floor finish thickness.

Tryphon

93,00



Tryphon Reduced

74,00



Tryphon Vertical

88,00

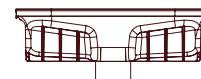

Complete shower kit Evolux Tryphon Kit

Evolux Lisa Anti-vandal



Product

Logistics

Finish	Tryphon			Tryphon Reduced			Measure	Membrane W-S	Units/ Box	Units/ Pallet	
	Ref.	Flow rate (l/min)		Ref.	Flow rate (l/min)						Model
		W.T.*	D.T.*		D.T.*						
●	IT41701	33	47	IT41701R	47		Lisa Antivand.	70 cm	2 x 2 · 4 m ²	6	40
●	IT41702	33	47	IT41702R	47		Lisa Antivand.	80 cm	2 x 2 · 4 m ²	6	40
●	IT41703	33	47	IT41703R	47		Lisa Antivand.	90 cm	2 x 2 · 4 m ²	6	40

*W.T.: Water Trap | D.T.: Dry Trap

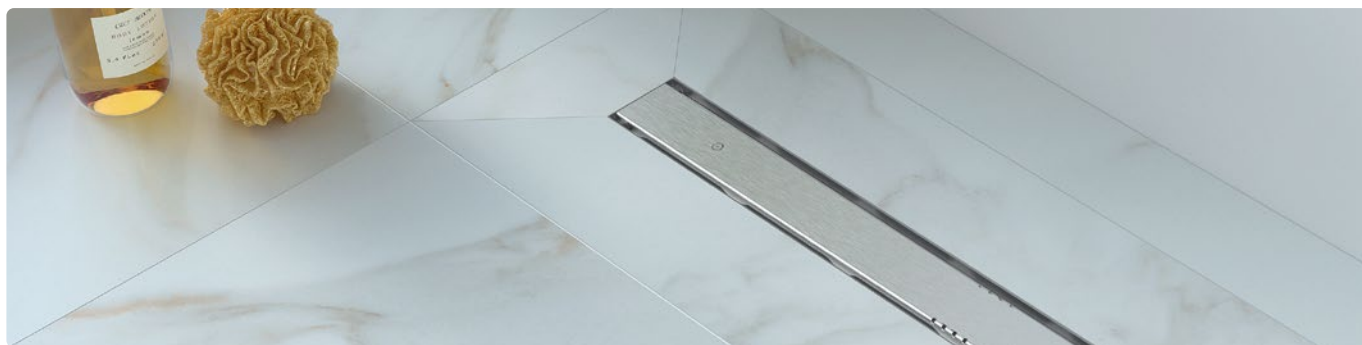

System contents

Drain to be selected

1

Option 1
Drain Tryphon



Option 2
Drain Tryphon Reduced



Complementary accessory

Tryphon Vertical body

*See more on page 87 (IG60032) ▶



System contents



1. Drain to be selected / 2. Evolux Lisa Anti-vandal grate and channel (selected size) and hair strainer / 3. Hook for lifting grates
4. Mortar level cap / 5. W-S Din x2 / 6. W-S Tub x2 / 7. Flexible Pushfit sleeve / 8. Water-Stop membrane with heat-sealed adapter (2 x 2 m)
9. Evolux Tryphon Kit box

Installation height

Including a 1 cm floor finish thickness.

Tryphon

93,00



Tryphon Reduced

74,00

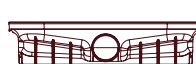

Tryphon Vertical

88,00

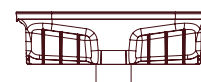

Complete shower kit Evolux Tryphon Kit

Evolux Lisa Gold



Product

Finish	Tryphon				Tryphon Reduced				Logistics		
	Ref.	Flow rate (l/min)		Ref.	Flow rate (l/min)		Model	Measure	Membrane W-S	Units/ Box	Units/ Pallet
		W.T.*	D.T.*		D.T.*	D.T.*					
●	IT61000	33	47	IT61000R	47		Lisa Gold	60 cm	2 x 2 · 4 m ²	6	40
●	IT61001	33	47	IT61001R	47		Lisa Gold	70 cm	2 x 2 · 4 m ²	6	40
●	IT61002	33	47	IT61002R	47		Lisa Gold	80 cm	2 x 2 · 4 m ²	6	40
●	IT61003	33	47	IT61003R	47		Lisa Gold	90 cm	2 x 2 · 4 m ²	6	40
●	IT61004	33	47	IT61004R	47		Lisa Gold	100 cm	2 x 2 · 4 m ²	6	40
●	IT61005	33	47	IT61005R	47		Lisa Gold	120 cm	2 x 2 · 4 m ²	3	32
●	IT61150	33	47	IT61150R	47		Lisa Gold	150 cm	2 x 2 · 4 m ²	3	32
●	IT61180	33	47	IT61180R	47		Lisa Gold	180 cm	2 x 2 · 4 m ²	3	32

*W.T.: Water Trap | D.T.: Dry Trap

System contents

Drain to be selected

1

Option 1
Drain Tryphon



Option 2
Drain Tryphon Reduced



Complementary accessory

Tryphon Vertical body

*See more on page 87 (IG60032)



System contents



1. Drain to be selected / 2. Evolux Lisa Gold grate and channel (selected size) and hair strainer / 3. Hook for lifting grates / 4. Mortar level cap
5. W-S Din x2 / 6. W-S Tub x2 / 7. Flexible Pushfit sleeve / 8. Water-Stop membrane with heat-sealed adapter (2 x 2 m) / 9. Evolux Tryphon Kit box

Installation height

Including a 1 cm floor finish thickness.

Tryphon

93,00



Tryphon Reduced

74,00



Tryphon Vertical

88,00



Complete shower kit Evolux Tryphon Kit

Evolux Lisa Dark



Product

Logistics

Finish	Tryphon		Tryphon Reduced		Model	Measure	Membrane W-S	Units/ Box	Units/ Pallet		
	Ref.	Flow rate (l/min)		Ref.						Flow rate (l/min)	
		W.T.*	D.T.*							D.T.*	
●	IT51000	33	47	IT51000R	47	Lisa Dark	60 cm	2 x 2 · 4 m ²	6	40	
●	IT51001	33	47	IT51001R	47	Lisa Dark	70 cm	2 x 2 · 4 m ²	6	40	
●	IT51002	33	47	IT51002R	47	Lisa Dark	80 cm	2 x 2 · 4 m ²	6	40	
●	IT51003	33	47	IT51003R	47	Lisa Dark	90 cm	2 x 2 · 4 m ²	6	40	
●	IT51004	33	47	IT51004R	47	Lisa Dark	100 cm	2 x 2 · 4 m ²	6	40	
●	IT51005	33	47	IT51005R	47	Lisa Dark	120 cm	2 x 2 · 4 m ²	3	32	
●	IT51150	33	47	IT51150R	47	Lisa Dark	150 cm	2 x 2 · 4 m ²	3	32	
●	IT51180	33	47	IT51180R	47	Lisa Dark	180 cm	2 x 2 · 4 m ²	3	32	

*W.T.: Water Trap | D.T.: Dry Trap

System contents

Drain to be selected

1

Option 1
Drain Tryphon



Option 2
Drain Tryphon Reduced



Complementary accessory

Tryphon Vertical body
*See more on page 87 (IG60032)



System contents



1. Drain to be selected / 2. Evolux Lisa Dark grate and channel (selected size) and hair strainer / 3. Hook for lifting grates / 4. Mortar level cap
5. W-S Din x2 / 6. W-S Tub x2 / 7. Flexible Pushfit sleeve / 8. Water-Stop membrane with heat-sealed adapter (2 x 2 m) / 9. Evolux Tryphon Kit box

Installation height

Including a 1 cm floor finish thickness.

Tryphon

93,00



Tryphon Reduced

74,00



Tryphon Vertical

88,00

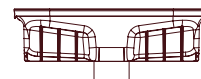

Complete shower kit Evolux Tryphon Kit

Evolux Microcement



Product									Logistics		
Finish	Tryphon			Tryphon Reduced			Measure	Membrane W-S	Units/ Box	Units/ Pallet	
	Ref.	Flow rate (l/min)		Ref.	Flow rate (l/min)						
		W.T.*	D.T.*		W.T.*	D.T.*					
●	IT47000	30	46	IT47000R	46		Microcement	60 cm	2 x 2 · 4 m ²	6	40
●	IT47001	30	46	IT47001R	46		Microcement	70 cm	2 x 2 · 4 m ²	6	40
●	IT47002	30	46	IT47002R	46		Microcement	80 cm	2 x 2 · 4 m ²	6	40
●	IT47003	30	46	IT47003R	46		Microcement	90 cm	2 x 2 · 4 m ²	6	40
●	IT47004	30	46	IT47004R	46		Microcement	100 cm	2 x 2 · 4 m ²	6	40
●	IT47005	30	46	IT47005R	46		Microcement	120 cm	2 x 2 · 4 m ²	3	32

*W.T.: Water Trap | D.T.: Dry Trap

System contents

Drain to be selected

1

Option 1
Drain Tryphon



Option 2
Drain Tryphon Reduced



Complementary accessory

Tryphon Vertical body

*See more on page 87 (IG60032)



System contents



1. Drain to be selected / 2. Evolux Microcement grate and channel (selected size) and hair strainer / 3. Installation template
4. Hook for lifting grates / 5. Mortar level cap / 6. W-S Din x2 / 7. W-S Tub x2 / 8. Flexible Pushfit sleeve
9. Water-Stop membrane with heat-sealed adapter (2 x 2 m) / 10. Evolux Tryphon Kit box

Installation height

Including a 1 cm floor finish thickness.

Tryphon

92,00



Tryphon Reduced

74,00



Tryphon Vertical

87,00

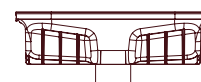

Complete shower kit Evolux Tryphon Kit Integra



New reduced 3 mm slot



Our shower kit **with integra grate** has been specifically designed for precise and safe installation of large-format ceramic tiles, since its dovetail Widhring system guarantees optimum grip.

Its **reinforced** aluminium structure combines strength and lightness, providing greater durability and stability during installation. In addition, its **new reduced 3 mm** slot is practically imperceptible, ensuring a more aesthetic finish that enhances the beauty of the ceramic covering.

<p>Features</p> <ul style="list-style-type: none"> Reinforced structure Maximum strength Lightweight Waterproofing included High drainage capacity Easy installation Effective cleaning 10-year warranty 		<p>System contents</p>
<p>Technical data</p> <ul style="list-style-type: none"> Textured stainless steel channel Aluminium grate with textured coating Dovetail grooves – maximum grip Self-centering grate with rubber stops 		<p>1. Evolux Integra grate / 2. Hair strainer / 3. Trap / 4. Evolux Integra channel / 5. Connection collector / 6. Water-Stop membrane / 7. Heat-sealed adapter / 8. Tryphon body / 9. Rubber stops flexible Pushfit sleeve</p>

Evolux Integra

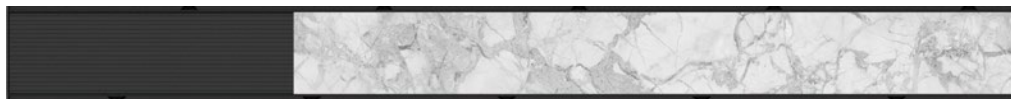

Product									Logistics		
Finish	Tryphon			Tryphon Reduced			Measure	Membrane W-S	Units/ Box	Units/ Pallet	
	Ref.	Flow rate (l/min)		Ref.	Flow rate (l/min)						Model
		W.T.*	D.T.*		W.T.*	D.T.*					
-	IT45040	32	47	IT45040R	47		Integra	40 cm	2 x 2 · 4 m ²	6	40
-	IT45050	32	47	IT45050R	47		Integra	50 cm	2 x 2 · 4 m ²	6	40
-	IT45000	32	47	IT45000R	47		Integra	60 cm	2 x 2 · 4 m ²	6	40
-	IT45001	32	47	IT45001R	47		Integra	70 cm	2 x 2 · 4 m ²	6	40
-	IT45002	32	47	IT45002R	47		Integra	80 cm	2 x 2 · 4 m ²	6	40
-	IT45003	32	47	IT45003R	47		Integra	90 cm	2 x 2 · 4 m ²	6	40
-	IT45004	32	47	IT45004R	47		Integra	100 cm	2 x 2 · 4 m ²	6	40
-	IT45005	32	47	IT45005R	47		Integra	120 cm	2 x 2 · 4 m ²	3	32
-	IT45150	32	47	IT45150R	47		Integra	150 cm	2 x 2 · 4 m ²	3	32
-	IT45180	32	47	IT45180R	47		Integra	180 cm	2 x 2 · 4 m ²	3	32

*W.T.: Water Trap | D.T.: Dry Trap

System contents

Drain to be selected **1**

Option 1
Drain Tryphon



Option 2
Drain Tryphon Reduced



Complementary accessory

Tryphon Vertical body

*See more on page 87 (IG60032) ▶



System contents



1. Drain to be selected / **2.** Evolux Integra grate and channel (selected size) and hair strainer / **3.** Installation template
4. Hook for lifting grates / **5.** Mortar level cap / **6.** W-S Din x2 / **7.** W-S Tub x2 / **8.** Flexible Pushfit sleeve
 Water-Stop membrane with heat-sealed adapter (2 x 2 m) / **9.** Evolux Tryphon Kit box

Installation height

Excluding installation floor finish thickness.

Tryphon

92,00

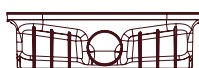

Tryphon Reduced

74,00



Tryphon Vertical

87,00

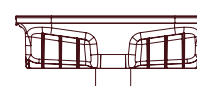

Complete shower kit Evolux Ruber Kit

Evolux Lisa



Product							Logistics	
Finish	Ruber H50	Ruber H28	Flow rate (l/min)	Model	Measure	Membrane	Units/Box	Units/Pallet
●	IE41040	IE41040R	27	Lisa	40 cm	2 x 2 · 4 m ²	6	40
●	IE41050	IE41050R	27	Lisa	50 cm	2 x 2 · 4 m ²	6	40
●	IE41000	IE41000R	27	Lisa	60 cm	2 x 2 · 4 m ²	6	40
●	IE41001	IE41001R	27	Lisa	70 cm	2 x 2 · 4 m ²	6	40
●	IE41002	IE41002R	27	Lisa	80 cm	2 x 2 · 4 m ²	6	40
●	IE41003	IE41003R	27	Lisa	90 cm	2 x 2 · 4 m ²	6	40
●	IE41004	IE41004R	27	Lisa	100 cm	2 x 2 · 4 m ²	6	40
●	IE41005	IE41005R	27	Lisa	120 cm	2 x 2 · 4 m ²	3	32
●	IE41150	IE41150R	27	Lisa	150 cm	2 x 2 · 4 m ²	3	32
●	IE41180	IE41180R	27	Lisa	180 cm	2 x 2 · 4 m ²	3	32

System contents

Drain to be selected 1

Option 1
Drain Ruber H50



Option 2
Drain Ruber H28

NOW INCLUDED



System contents



1. Drain to be selected / 2. Evolux Lisa grate and channel (selected size) and hair strainer / 3. Hook for lifting grates / 4. Mortar level cap
5. W-S Din x2 / 6. W-S Tub x2 / 7. Water-Stop membrane with heat-sealed adapter (2 x 2 m) / 8. Evolux Ruber Kit box

Installation height

Including a 1 cm floor finish thickness.

Ruber H50

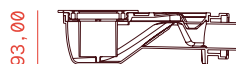

Ruber H28



Complete shower kit Evolux Ruber Kit

Evolux Plus



Product							Logistics	
Finish	Ruber H50	Ruber H28	Flow rate (l/min)	Model	Measure	Membrane	Units/Box	Units/Pallet
●	IE42000	IE42000R	28	Plus	60 cm	2 x 2 · 4 m ²	6	40
●	IE42001	IE42001R	28	Plus	70 cm	2 x 2 · 4 m ²	6	40
●	IE42002	IE42002R	28	Plus	80 cm	2 x 2 · 4 m ²	6	40
●	IE42003	IE42003R	28	Plus	90 cm	2 x 2 · 4 m ²	6	40
●	IE42004	IE42004R	28	Plus	100 cm	2 x 2 · 4 m ²	6	40
●	IE42005	IE42005R	28	Plus	120 cm	2 x 2 · 4 m ²	3	32
●	IE42150	IE42150R	28	Plus	150 cm	2 x 2 · 4 m ²	3	32
●	IE42180	IE42180R	28	Plus	180 cm	2 x 2 · 4 m ²	3	32

System contents

Drain to be selected

1

Option 1
Drain Ruber H50



Option 2
Drain Ruber H28

NOW INCLUDED



System contents



1. Drain to be selected / 2. Evolux Plus grate and channel (selected size) and hair strainer / 3. Hook for lifting grates / 4. Mortar level cap
5. W-S Din x2 / 6. W-S Tub x2 / 7. Water-Stop membrane with heat-sealed adapter (2 x 2 m) / 8. Evolux Ruber Kit box

Installation height

Including a 1 cm floor finish thickness.

Ruber H50

93,00

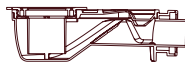

Ruber H28

73,00

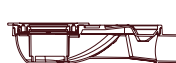

Complete shower kit Evolux Ruber Kit

Evolux Lisa Anti-vandal



Product							Logistics	
Finish	Ruber H50	Ruber H28	Flow rate (l/min)	Model	Measure	Membrane	Units/Box	Units/Pallet
	IE41701	IE41701R	27	Lisa Antivandal.	70 cm	2 x 2 · 4 m ²	6	40
	IE41702	IE41702R	27	Lisa Antivandal.	80 cm	2 x 2 · 4 m ²	6	40
	IE41703	IE41703R	27	Lisa Antivandal.	90 cm	2 x 2 · 4 m ²	6	40



System contents

Drain to be selected

1

Option 1

Drain Ruber H50



Option 2

Drain Ruber H28

NOW INCLUDED



System contents



1. Drain to be selected / 2. Evolux Lisa Anti-vandal grate and channel (size to be selected) and hair strainer / 3. Hook for lifting grates
4. Mortar levelling cap / 5. W-S Din x2 / 6. W-S Tub x2 / 7. Water-Stop membrane with heat-sealed adapter (2 x 2 m) / 8. Evolux Ruber Kit box

Installation height

Including a 1 cm floor finish thickness.

Ruber H50

93,00

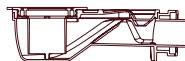

Ruber H28

73,00



Complete shower kit Evolux Ruber Kit

Evolux Lisa Gold



Product							Logistics	
Finish	Ruber H50	Ruber H28	Flow rate (l/min)	Model	Measure	Membrane	Units/Box	Units/Pallet
●	IE61000	IE61000R	27	Lisa Gold	60 cm	2 x 2 · 4 m ²	6	40
●	IE61001	IE61001R	27	Lisa Gold	70 cm	2 x 2 · 4 m ²	6	40
●	IE61002	IE61002R	27	Lisa Gold	80 cm	2 x 2 · 4 m ²	6	40
●	IE61003	IE61003R	27	Lisa Gold	90 cm	2 x 2 · 4 m ²	6	40



System contents

Drain to be selected

1

Option 1
Drain Ruber H50



Option 2
Drain Ruber H28

NOW INCLUDED



System contents



1. Drain to be selected / 2. Evolux Lisa Gold grate and channel (size to be selected) and hair strainer / 3. Hook for lifting grates / 4. Mortar levelling cap
5. W-S Din x2 / 6. W-S Tub x2 / 7. Water-Stop membrane with heat-sealed adapter (2 x 2 m) / 8. Evolux Ruber Kit box

Installation height

Including a 1 cm floor finish thickness.

Ruber H50

93,00

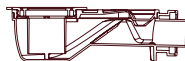

Ruber H28

73,00



Complete shower kit Evolux Ruber Kit

Evolux Lisa Dark



Product							Logistics	
Finish	Ruber H50	Ruber H28	Flow rate (l/min)	Model	Measure	Membrane	Units/Box	Units/Pallet
●	IE51000	IE51000R	27	Lisa Dark	60 cm	2 x 2 · 4 m ²	6	40
●	IE51001	IE51001R	27	Lisa Dark	70 cm	2 x 2 · 4 m ²	6	40
●	IE51002	IE51002R	27	Lisa Dark	80 cm	2 x 2 · 4 m ²	6	40
●	IE51003	IE51003R	27	Lisa Dark	90 cm	2 x 2 · 4 m ²	6	40
●	IE51004	IE51004R	27	Lisa Dark	100 cm	2 x 2 · 4 m ²	6	40
●	IE51005	IE51005R	27	Lisa Dark	120 cm	2 x 2 · 4 m ²	3	32
●	IE51150	IE51150R	27	Lisa Dark	150 cm	2 x 2 · 4 m ²	3	32
●	IE51180	IE51180R	27	Lisa Dark	180 cm	2 x 2 · 4 m ²	3	32



System contents

Drain to be selected

1

Option 1
Drain Ruber H50



Option 2
Drain Ruber H28

NOW INCLUDED



System contents



1. Drain to be selected / 2. Evolux Lisa Dark grate and channel (size to be selected) and hair strainer / 3. Hook for lifting grates
4. Mortar levelling cap / 5. W-S Din x2 / 6. W-S Tub x2 / 7. Water-Stop membrane with heat-sealed adapter (2 x 2 m) / 8. Evolux Ruber Kit box

Installation height

Including a 1 cm floor finish thickness.

Ruber H50

93,00

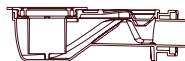

Ruber H28

73,00



Complete shower kit Evolux Ruber Kit

Evolux Microcement

/ Gold
/ Dark



Product							Logistics	
Finish	Ruber H50	Ruber H28	Flow rate (l/min)	Model	Measure	Membrane	Units/Box	Units/Pallet
●	IE47000	IE47000R	24	Microcement	60 cm	2 x 2 · 4 m ²	6	40
●	IE47001	IE47001R	24	Microcement	70 cm	2 x 2 · 4 m ²	6	40
●	IE47002	IE47002R	24	Microcement	80 cm	2 x 2 · 4 m ²	6	40
●	IE47003	IE47003R	24	Microcement	90 cm	2 x 2 · 4 m ²	6	40
●	IE47004	IE47004R	24	Microcement	100 cm	2 x 2 · 4 m ²	6	40
●	IE47005	IE47005R	24	Microcement	120 cm	2 x 2 · 4 m ²	3	32
●	IE67000	IE67000R	24	Micro Gold	60 cm	2 x 2 · 4 m ²	6	40
●	IE67001	IE67001R	24	Micro Gold	70 cm	2 x 2 · 4 m ²	6	40
●	IE67002	IE67002R	24	Micro Gold	80 cm	2 x 2 · 4 m ²	6	40
●	IE67003	IE67003R	24	Micro Gold	90 cm	2 x 2 · 4 m ²	6	40
●	IE57000	IE57000R	24	Micro Dark	60 cm	2 x 2 · 4 m ²	6	40
●	IE57001	IE57001R	24	Micro Dark	70 cm	2 x 2 · 4 m ²	6	40
●	IE57002	IE57002R	24	Micro Dark	80 cm	2 x 2 · 4 m ²	6	40
●	IE57003	IE57003R	24	Micro Dark	90 cm	2 x 2 · 4 m ²	6	40
●	IE57004	IE57004R	24	Micro Dark	100 cm	2 x 2 · 4 m ²	6	40
●	IE57005	IE57005R	24	Micro Dark	120 cm	2 x 2 · 4 m ²	3	32

System contents

Drain to be selected

1

Option 1
Drain Ruber H50



Option 2
Drain Ruber H28

NOW INCLUDED



System contents



1. Drain to be selected / 2. Evolux Microcement grate and channel (size to be selected) and hair strainer / 3. Installation template
4. Hook for lifting grates / 5. Mortar levelling cap / 6. W-S Din x2 / 7. W-S Tub x2 / 8. Flexible Pushfit sleeve
9. Water-Stop membrane with heat-sealed adapter (2 x 2 m) / 10. Evolux Ruber Kit box

Installation height

Ruber H50

93,00

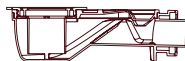

Ruber H28

73,00



Complete shower kit **Evolux Ruber Kit**

Evolux Integra



Product							Logistics	
Finish	Ruber H50	Ruber H28	Flow rate (l/min)	Model	Measure	Membrane	Units/Box	Units/Pallet
-	IE45040	IE45040R	27	Integra	40 cm	2 x 2 · 4 m ²	6	40
-	IE45050	IE45050R	27	Integra	50 cm	2 x 2 · 4 m ²	6	40
-	IE45000	IE45000R	27	Integra	60 cm	2 x 2 · 4 m ²	6	40
-	IE45001	IE45001R	27	Integra	70 cm	2 x 2 · 4 m ²	6	40
-	IE45002	IE45002R	27	Integra	80 cm	2 x 2 · 4 m ²	6	40
-	IE45003	IE45003R	27	Integra	90 cm	2 x 2 · 4 m ²	6	40
-	IE45004	IE45004R	27	Integra	100 cm	2 x 2 · 4 m ²	6	40
-	IE45005	IE45005R	27	Integra	120 cm	2 x 2 · 4 m ²	3	32



System contents

Drain to be selected

1

Option 1
Drain Ruber H50



Option 2
Drain Ruber H28

NOW INCLUDED



System contents



1. Drain to be selected / 2. Evolux Integra grate and channel (size to be selected) and hair strainer / 3. Installation template
4. Hook for lifting grates / 5. Mortar levelling cap / 6. W-S Din x2 / 7. W-S Tub x2 / 8. Flexible Pushfit sleeve
9. Water-Stop membrane with heat-sealed adapter (2 x 2 m) / 10. Evolux Ruber Kit box

Installation height

Excluding installation floor finish thickness.

Ruber H50

93,00

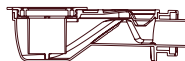

Ruber H28

73,00



Complete shower kit Evolux Ruber Kit

Evolux Cristal



Product							Logistics	
Finish	Ruber H50	Ruber H28	Flow rate (l/min)	Model	Measure	Membrane	Units/Box	Units/Pallet
○	IE49001	IE49001R	27	Cristal	70 cm	2 x 2 · 4 m ²	6	40
○	IE49002	IE49002R	27	Cristal	80 cm	2 x 2 · 4 m ²	6	40
○	IE49003	IE49003R	27	Cristal	90 cm	2 x 2 · 4 m ²	6	40



System contents

Drain to be selected

1

Option 1
Drain Ruber H50



Option 2
Drain Ruber H28

NOW INCLUDED



System contents



1. Drain to be selected / 2. Evolux Lisa Gold grate and channel (size to be selected) and hair strainer / 3. Hook for lifting grates / 4. Mortar levelling cap
5. W-S Din x2 / 6. W-S Tub x2 / 7. Water-Stop membrane with heat-sealed adapter (2 x 2 m) / 8. Evolux Ruber Kit box

Installation height

Including a 1 cm floor finish thickness.

Ruber H50

93,00

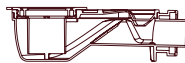

Ruber H28

73,00

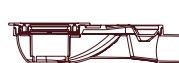

Evolux Vinyl Shower kit for vinyl floors

EVOLUX VINYL is our latest innovation in drains for vinyl floors. It stands out for the watertightness achieved in bathrooms, changing rooms, etc, together with easy installation.

This kit consists of a channel and a frame with trim which, by means of a watertight clamping system with MS sealant, allows installation of the drain in technical floors in hospitals, laboratories, wet rooms, etc.

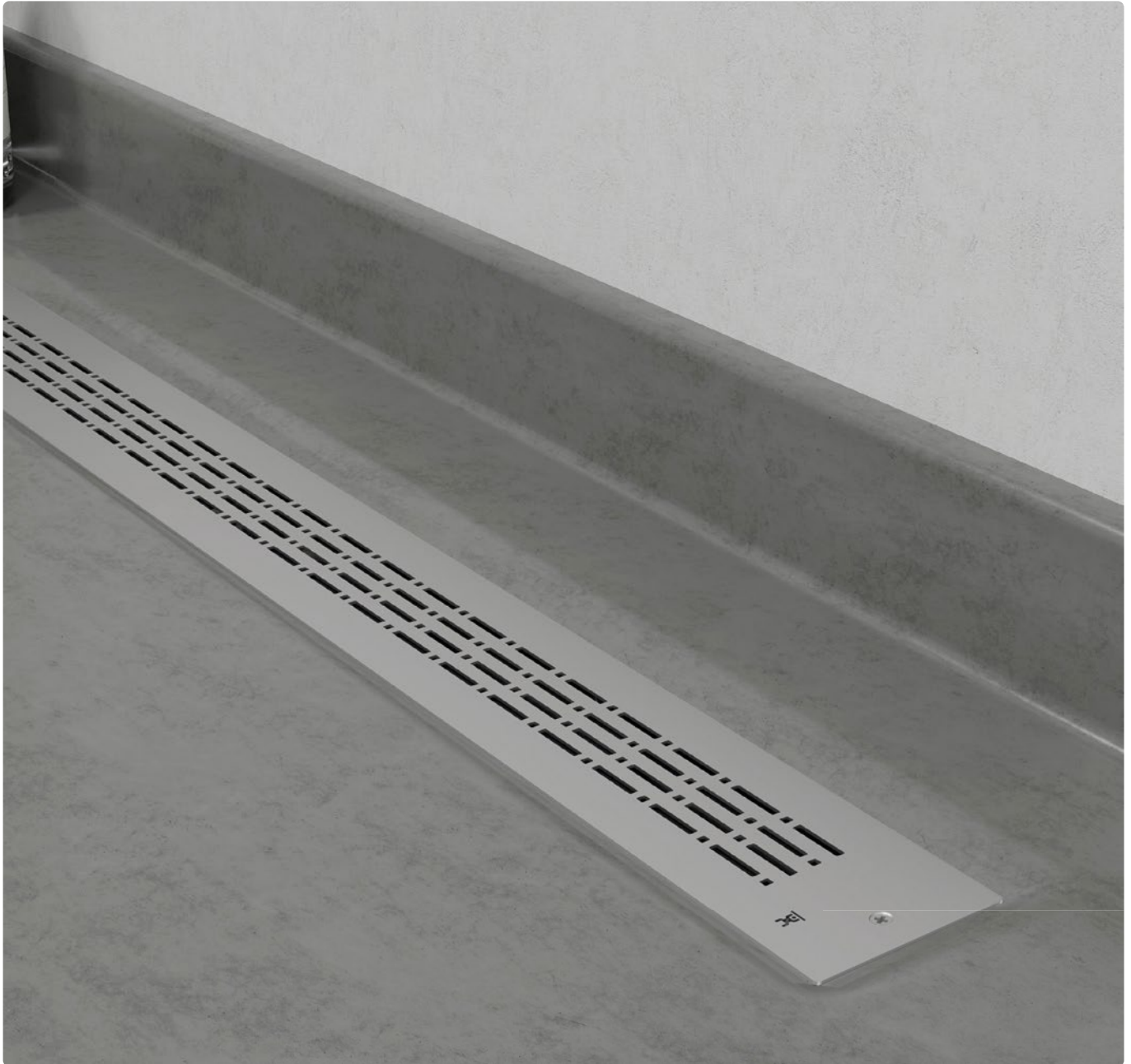

Point option



Linear option



Features	Stainless steel structure
	Guaranteed watertightness
	High drainage capacity
	Removable hair strainer included
	Self-cleaning drain
	Easy installation



1. Evolux Integra grate / 2. Frame / 3. Hair strainer / 4. Evolux Vinyl channel / 5. Adapter / 6. Ruber collar / 7. Ruber drain / 8. Ø50/40 mm reducer

Technical data	Accepts vinyl floors from 1 to 5 mm
	Anti-vandal
	Stainless steel

System contents

Drain to be selected



Option 1
Drain Ruber H50

Option 2
Drain Ruber H28

NOW INCLUDED



System contents



1. Drain to be selected / 2. Evolux Vinyl grate and channel (size to be selected)*, hair strainer and screws / 3. Hook for lifting grates / 4. W-S Mastic / 5. Mortar levelling cap / 6. Installation template / 7. Evolux Ruber Kit box

Installation height

Including a 1 cm floor finish thickness.

Ruber H50

93.00

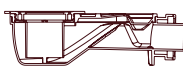

Ruber H28

73.00

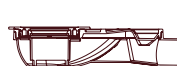

Product				Logistics	
Ref. Ruber H50	Ref. Ruber H28	Model	Measure	Units/Box	Units/Pallet
IE70008	IE70008R	Vinyl	15 x 15 cm	3	50
IE70001	IE70001R	Vinyl	70 cm	6	40
IE70002	IE70002R	Vinyl	80 cm	6	40
IE70003	IE70003R	Vinyl	90 cm	6	40
IE70004	IE70004R	Vinyl	100 cm	6	40

Evolux Kit Complete point shower kit with Ruber drain



Product							Logistics	
Finish	Ruber H50	Ruber H28	Flow rate (l/min)	Model	Measure	Membrane	Units/Box	Units/Pallet
●	IE41008	IE41008R	26	Lisa	11,6 × 11,6 cm	1,5 x 2 · 3 m ²	3	50
●	IE41009	IE41009R	27	Lisa	15 × 30 cm	1,5 x 2 · 3 m ²	3	50
●	IE41708	IE41708R	26	Lisa Antivandal	11,6 × 11,6 cm	1,5 x 2 · 3 m ²	3	50
●	IE42008	IE42008R	28	Plus	11,6 × 11,6 cm	1,5 x 2 · 3 m ²	3	50
●	IE42009	IE42009R	29	Plus	15 × 30 cm	1,5 x 2 · 3 m ²	3	50
●	IE42708	IE42708R	26	Plus Antivandal	11,6 × 11,6 cm	1,5 x 2 · 3 m ²	3	50
●	IE51008	IE51008R	26	Lisa Dark	11,6 × 11,6 cm	1,5 x 2 · 3 m ²	3	50
●	IE51009	IE51009R	27	Lisa Dark	15 × 30 cm	1,5 x 2 · 3 m ²	3	50
●	IE61108	IE61108R	26	Lisa Light	11,6 × 11,6 cm	1,5 x 2 · 3 m ²	3	50
●	IE62108	IE62108R	28	Plus Light	11,6 × 11,6 cm	1,5 x 2 · 3 m ²	3	50
●	IE47008	IE47008R	25	Microcement	11,6 × 11,6 cm	1,5 x 2 · 3 m ²	3	50
●	IE47009	IE47009R	26	Microcement	15 × 30 cm	1,5 x 2 · 3 m ²	3	50
●	IE67008	IE67008R	25	Micro Gold	11,6 × 11,6 cm	1,5 x 2 · 3 m ²	3	50
●	IE67009	IE67009R	26	Micro Gold	15 × 30 cm	1,5 x 2 · 3 m ²	3	50
●	IE57008	IE57008R	25	Micro Dark	11,6 × 11,6 cm	1,5 x 2 · 3 m ²	3	50
●	IE57009	IE57009R	26	Micro Dark	15 × 30 cm	1,5 x 2 · 3 m ²	3	50
○	IE49009	IE49009R	27	Cristal	15 × 30 cm	1,5 x 2 · 3 m ²	3	50
-	IE45008	IE45008R	26	Integra	11,6 × 11,6 cm	1,5 x 2 · 3 m ²	3	50
-	IE45009	IE45009R	25	Integra	15 × 30 cm	1,5 x 2 · 3 m ²	3	50

The Evolux Point version offers the same waterproofing and efficient drainage performance in a **compact and discreet format**.

Its point design facilitates integration into shower trays of reduced dimensions, while maintaining the same quality and reliability as the Evolux Linear system.

Features

- Stainless steel structure
- High load resistance
- Waterproofing included
- High drainage capacity
- Easy installation
- Effective cleaning
- 10-year warranty

Components

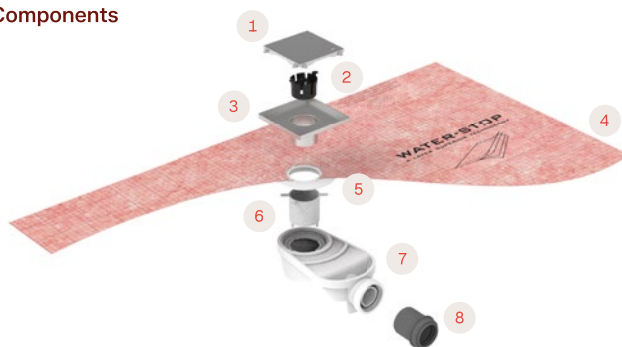

- 1. Evolux grate / 2. Hair strainer / 3. Evolux body
- 4. Water-Stop membrane / 5. Adapter / 6. Ruber drain / 7. Ø50/40 mm reducer

Technical data

- Elastic joints
- Secondary drainage
- 360° orientable

Models

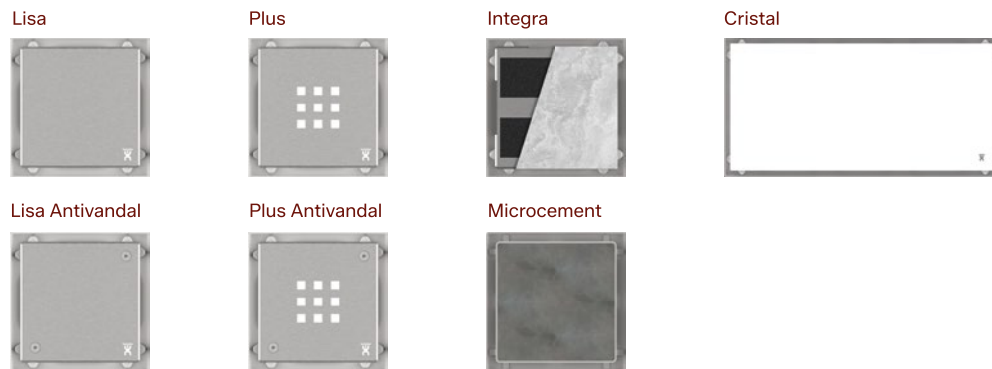

System contents

Drain to be selected

Option 1
Drain Ruber H50



Option 2
Drain Ruber H28
NOW INCLUDED



System contents



- 1. Drain to be selected / 2. Evolux grate and channel (size to be selected) and hair strainer / 3. Hook for lifting grates / 4. Mortar levelling cap
- 5. W-S Din x2 / 6. W-S Tub x2 / 7. Water-Stop membrane with heat-sealed adapter (1.5 x 2 m) / 8. Evolux Ruber Kit box

Installation height

Including a 1 cm floor finish thickness.

Ruber H50

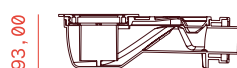

Ruber H28



System Evo

Complete shower kit

Plus Evo



Evo



Onde Evo



Disuasoria



Evo Colors

Polished

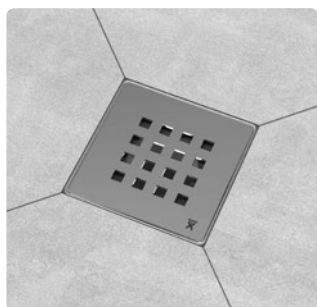

Black

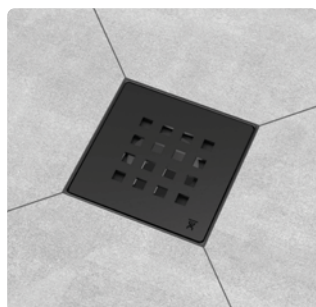

Bronze

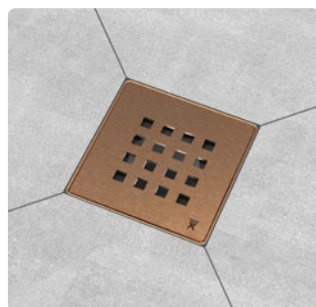

Gold

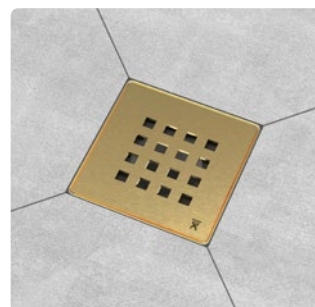

The Evo System is a **shower system with integrated waterproofing**, consisting of a low-profile trapped drain, a Water-Stop waterproof membrane factory-bonded and sealed to a special adapter for its direct connection to the drain, and a stainless steel grate with ABS body.

Features

- Waterproofing included
- Offset drain position
- High drainage capacity
- Easy installation
- Removable hair strainer
- 10-year warranty

Components



- 1. Evo grate / 2. Hair strainer / 3. Evo body
- 4. Water-Stop membrane / 5. Adapter / 6. Ruber collar
- 7. Ruber drain / 8. Ø50/40 mm reducer

Technical data

- Elastic joints
- Secondary drainage
- 360° adjustable

System contents

Drain to be selected

Option 1
Drain Ruber H50



Option 2
Drain Ruber H28

NOW INCLUDED



System contents



- 1. Drain of choice / 2. Evolux grate and channel (size to be selected) with hair strainer / 3. Hook for lifting grates / 4. Mortar level cover / 5. W-S Din x2 / 6. W-S Tub x2 / 7. Water-Stop membrane with factory heat-welded adapter (1.5 x 2 m / 2 x 2 m) / 8. Evolux Point Kit box

Installation height

Including a 1 cm floor finish thickness.

Ruber H50

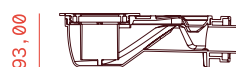

Ruber H28



Product

Finish	Product			Model	Membrane	Logistics	
	Ruber H50	Ruber H28	Flow rate (l/min)			Units/Box	Units/Pallet
●	IB20015	IB20015R	24	System Evo	1,5 x 2 · 3 m ²	6	84
●	IB20016	IB20016R	26	System Plus Evo	1,5 x 2 · 3 m ²	6	84
●	IB20017	IB20017R	26	System Onde Evo	1,5 x 2 · 3 m ²	6	84
●	IB20007	IB20007R	26	System Disuasoria	1,5 x 2 · 3 m ²	6	84
●	IB20018	IB20018R	26	System Plus Evo Polished	1,5 x 2 · 3 m ²	6	84
●	IB20019	IB20019R	26	System Plus Evo Black	1,5 x 2 · 3 m ²	6	84
●	IB20020	IB20020R	26	System Plus Evo Bronze	1,5 x 2 · 3 m ²	6	84
●	IB20021	IB20021R	26	System Plus Evo Gold	1,5 x 2 · 3 m ²	6	84

W-S Bathkit Complete bathtub kit





The W-S Bathkit bathtub kit is a **click-clack drainage** system with overflow for **built-in bathtubs**.

The system ensures a perfect connection between the Water-Stop waterproofing membrane and the drain, thus preventing any type of leakage or dampness.



Features

- Waterproofing included
- High drainage capacity
- Available in different finishes
- Easy installation

Technical data

- Click-clack valve
- Integrated overflow
- High-resistance PVD and lacquered finishes
- Flexible pipe up to 680 mm
- Ø40 mm outlet pipe

Finishes

Inox



Gold



Dark



White



Chrome



Old Bronze



System contents

W-S Bathkit



1. Click-clack valve with stopper* / 2. Drain with integrated waterproofing membrane / 3. Overflow with trim cover*, integrated waterproofing membrane + pipe / 4. Adjustable trap / 5. W-S MASTIC (x2) / 6. WATER-STOP membrane 2 x 3 m / 7. WATER-STOP roll 1 x 5 m / 8. W-S Bathkit box.

*Available in various finishes. See the table below.

W-S Bath



1. Click-clack valve with stopper* / 2. Drain with integrated waterproofing membrane / 3. Overflow with trim cover*, integrated waterproofing membrane + pipe / 4. Adjustable trap / 5. W-S Bath box.

*Available in various finishes. See the table below.

Product				Logistics	
Finish	Ref.	Description	Membrane W-S	Units/Box	Units/Pallet
	IA11000	W-S Bathkit Inox	2 x 3 · 6 m ²	4	40
	IA11020	W-S Bathkit Gold	2 x 3 · 6 m ²	4	40
	IA11021	W-S Bathkit Dark	2 x 3 · 6 m ²	4	40
	IA11030	W-S Bathkit White	2 x 3 · 6 m ²	4	40
	IA11031	W-S Bathkit Chrome	2 x 3 · 6 m ²	4	40
	IA11034	W-S Bathkit Old Bronze	2 x 3 · 6 m ²	4	40
	IA11022	W-S Bath Inox	-	6	94
	IA11023	W-S Bath Gold	-	6	94
	IA11024	W-S Bath Dark	-	6	94
	IA11025	W-S Bath White	-	6	94
	IA11026	W-S Bath Chrome	-	6	94
	IA11029	W-S Bath Old Bronze	-	6	94

Improved performance, exclusive finishes.

Precise engineering and material quality ensure long-lasting performance, while attention to detail in the finishes allows elegant integration into any project.

SafeBand

Anti-leakage strip



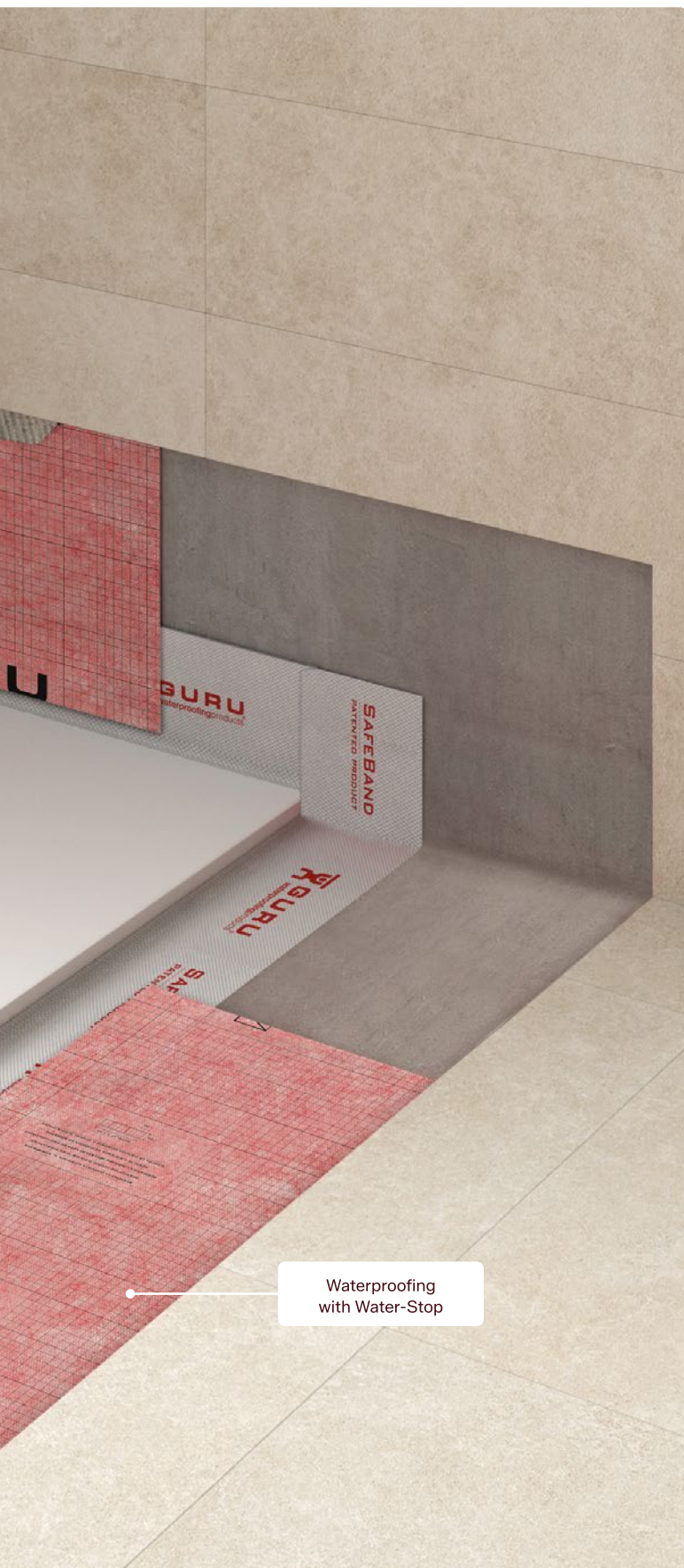

Say goodbye to silicone problems with SafeBand

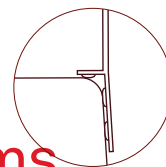

SafeBand is a multiaxial, **flexible anti-leakage strip** that guarantees watertight sealing at wall-to-floor junctions, making it the ideal replacement for silicone in the installation of shower trays and bathtubs..

Why choose SafeBand?

Its GURU-**patented** design provides strong fixing and a dual barrier against leakage, solving the usual problems associated with silicone, such as low durability, mould and moisture formation, and the risk of leaks.

This advanced sealing system complies with the requirements of DIN 18534, and its performance has been verified by the independent Kiwa institute in accordance with ETAG 022-2.



Product			Logistics	
Ref.	Description	Measure	Units/Box	Units/Pallet
IG66016	Kit SafeBand	2 m x 14 cm	12	324
IG66001	Kit SafeBand	3,5 m x 14 cm	12	324
IG66002	Kit SafeBand	6 m x 14 cm	12	324
IG66003	Kit SafeBand	30 m x 14 cm	6	54



SafeBand is an ideal solution for **shower trays and bathtubs**, as it effectively eliminates leakage and damage, guaranteeing total watertightness at the joints between the tray or bathtub and the walls and floor.

Features

- Barrier on two different planes
- Flexible and elastic material
- Fibres on both sides to improve adhesion to the substrate
- Extra-strong fixing
- 12 cm upstand

Technical data

- Weight (gr): 250
- Width (cm): 14
- Length (m): 2, 3'5, 6, 30
- Elongation: 65%

Composition

Non-woven fibres:
50% polyester + 50% polypropylene

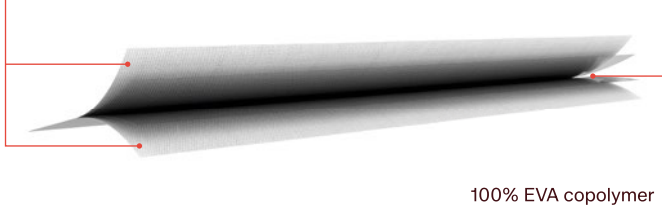

System components



1. SafeBand / 2. Applicator / 3. Butyl / 4. SafeBand Kit box



Shelf

Shower shelves



Shelf is a shower shelf that does **not require drilling or perforations for installation**, preventing damage to walls and eliminating the need for building work.

Manufactured in AISI 316 stainless steel (marine grade), it offers high corrosion resistance, combining durability and aesthetics. Its 1 mm thickness design allows installation in 1.5 mm joints between tiles.

It stands out for its **high load capacity**, above standard levels, and for its **quick and precise installation**, in less than 30 minutes.

<p>Features</p> <ul style="list-style-type: none"> Easy installation in renovation projects and new builds Unique aesthetic finishes Standard: UNE67100 No-drill installation (no risk of pipe damage or loss of waterproofing) 	<p>Technical data</p> <ul style="list-style-type: none"> Thickness: 1 mm Manufactured in AISI 316 steel - Marine Grade PVD, textured and satin finishes
--	---

Measures (mm)

Triangular Plus

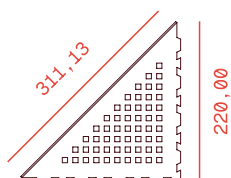

Triangular Beat

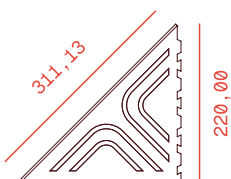

Trapezoid Plus

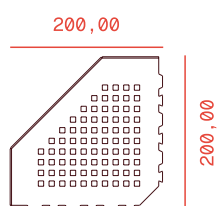

Trapezoid Beat

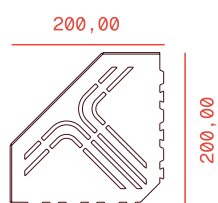

Trapezoid Asim Plus

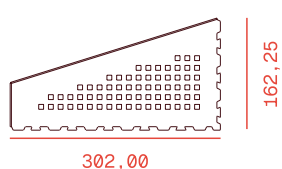

Models and Finishes

Triangular Plus



Triangular Beat



Trapezoid Plus

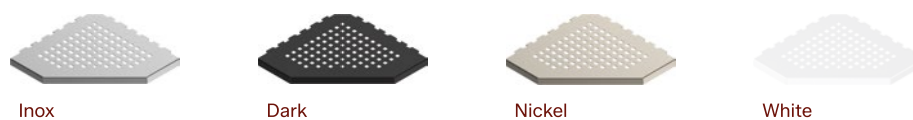

Trapezoid Beat

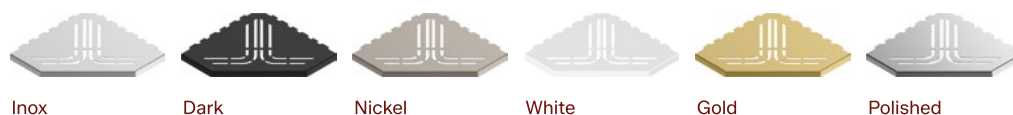

Trapezoid Asim Plus

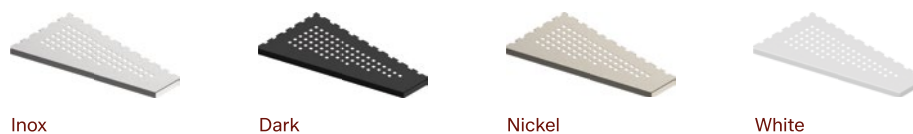

Install your shower shelf without the need for building work

A practical and elegant solution that allows storage to be incorporated into the shower quickly and easily. Designed for clean and efficient installation, without renovation work or complications, and with finishes that integrate perfectly into any bathroom space.

Product				Logistics	
Ref.	Shape	Model	Finish	Units/Box	Units/Pallet
IZU0302	Triangle	Plus	Inox	11	297
IZU0301	Triangle	Plus	Dark	11	297
IZU0314	Triangle	Plus	Nickel	11	297
IZU0300	Triangle	Plus	White	11	297
IZU0004	Triangle	Beat	Inox	11	297
IZU0000	Triangle	Beat	Dark	11	297
IZU0005	Triangle	Beat	Nickel	11	297
IZU0305	Trapezoid	Plus	Inox	11	297
IZU0304	Trapezoid	Plus	Dark	11	297
IZU0312	Trapezoid	Plus	Nickel	11	297
IZU0303	Trapezoid	Plus	White	11	297
IZU0006	Trapezoid	Beat	Inox	11	297
IZU0001	Trapezoid	Beat	Dark	11	297
IZU0007	Trapezoid	Beat	Nickel	11	297
IZU0008	Trapezoid	Beat	White	11	297
IZU0009	Trapezoid	Beat	Gold	11	297
IZU0010	Trapezoid	Beat	Polished	11	297
IZU0308	Trapezoid Asim	Plus	Inox	11	297
IZU0307	Trapezoid Asim	Plus	Dark	11	297
IZU0313	Trapezoid Asim	Plus	Nickel	11	297
IZU0306	Trapezoid Asim	Plus	White	11	297

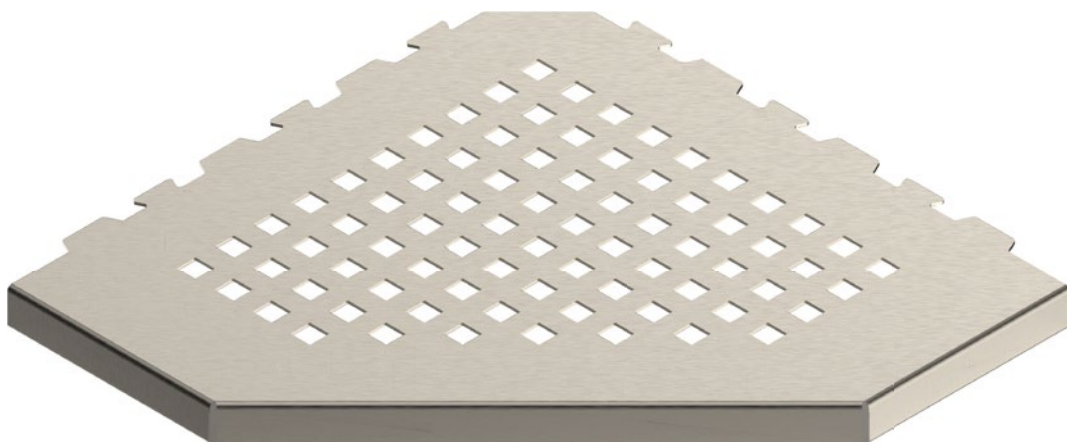

Installation Profiles

G-Pro Level

Decorative finishing profiles manufactured in high-quality stainless steel to clad the lateral slope of the built-in shower. They ensure a constant 2% slope in accordance with the CTE (Technical Building Code).

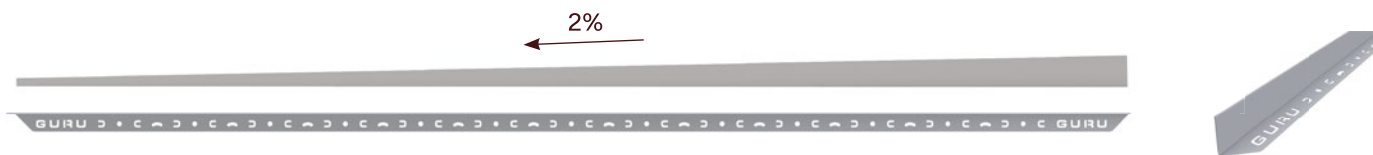

Left profile

Ref.	Description	Finish
IJ80016	G-Pro Level 180 cm - Left	Inox ●
IJ80026	G-Pro Level 180 cm - Left	White ○
IJ80028	G-Pro Level 180 cm - Left	Dark ●

Right profile

Ref.	Description	Finish
IJ80030	G-Pro Level 180 cm - Right	Inox ●
IJ80040	G-Pro Level 180 cm - Right	White ○
IJ80042	G-Pro Level 180 cm - Right	Dark ●

G-Pro Wall

Profiles used in wall-adjacent installation.



Ref.	Description
IJ80008	G-Pro Wall 11,6 cm
IJ80009	G-Pro Wall 15 cm
IJ80006	G-Pro Wall 30 cm
IJ80007	G-Pro Wall 40 cm
IJ80000	G-Pro Wall 60 cm
IJ80001	G-Pro Wall 70 cm

Ref.	Description
IJ80002	G-Pro Wall 80 cm
IJ80003	G-Pro Wall 90 cm
IJ80004	G-Pro Wall 100 cm
IJ80005	G-Pro Wall 120 cm
IJ80013	G-Pro Wall 150 cm
IJ80014	G-Pro Wall 180 cm

Installation Accessories Evo/Evolux

Joining bracket

The Evolux shower system family is designed to be joined together without the need for fastening by means of our stainless steel joining bracket.

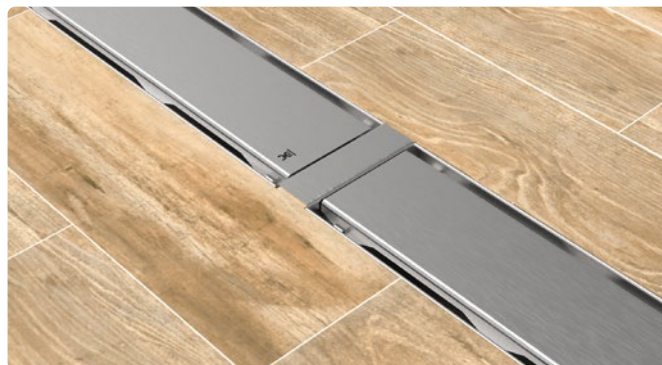

Ref.	Description	Finish
IG67004	Joining bracket	Satin

Vertical outlet adapter for under-slab installation

Ruber drain adaptation kit for under-slab vertical outlet installation. It consists of an extension and an adapter.

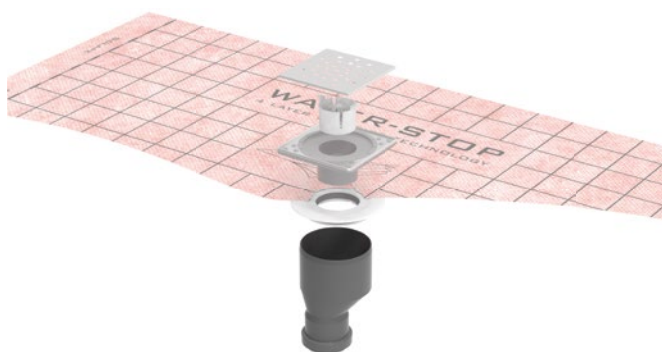

Ref.	Description	Finish
IG01143	Under-slab system	Polypropylene

Hair strainer

Pack of 25 ABS hair strainers.



Ref.	Description	Finish
IG60034	Pack 25 Hair strainer	ABS

Installation Accessories Evo/Evolux

Water-Stop 40 × 40 cm

40 × 40 cm Water-Stop sheet piece with adapter to the Ruber or Tryphon drain, factory heat-sealed.

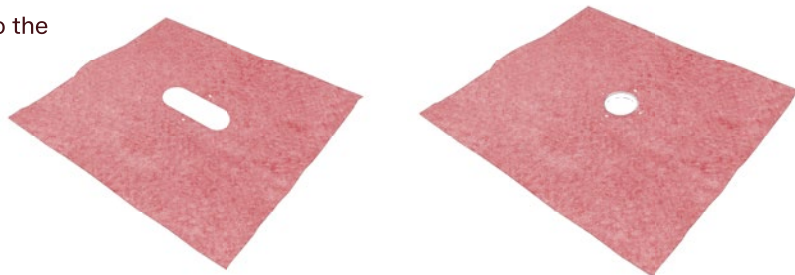

Ref.	Description
------	-------------

IF55016	Adapter Ruber with Membrane de 40 × 40 cm
---------	---

IF55046	Adapter Tryphon with Membrane de 40 × 40 cm
---------	---

Ruber Drain Kit

Standard-height and reduced-height option.



Ref.	Description
------	-------------

IG60035	Kit Drain Ruber H50
---------	---------------------

IG60030	Kit Drain Ruber H28 Reduced
---------	-----------------------------

Tryphon Drain Kit

Standard-height and reduced-height option, plus vertical outlet option.



Ref.	Description
------	-------------

IG60036	Body Tryphon
---------	--------------

IG60031	Tryphon Reduced body
---------	----------------------

IG60032	Tryphon Vertical body
---------	-----------------------

Installation Accessories

Adhesives

Easeal

Single-component mortar.
Elastic and flexible waterproofing.



W-S Mastic

High-modulus MS polymer
sealing adhesive.



NEW Product

W-S Oneseal

Single-component modified
polyurethane adhesive.



Ref.	Description	Measure	Format	Coverage
IG60023	Easeal	20 kg	Bag	Variable *
IG60024	Easeal	3 kg	Bucket	Variable *
IG64000	W-S Mastic	290 m	Pipe	6 m
IG65000	W-S Oneseal	6 kg	Bucket	Variable *
IG65001	W-S Oneseal	600 ml	Sausage	Variable *

*See technical data sheet for coverage. ►

Joining elements

W-S Band 14 / 34

Reinforcement and finishing at junctions
with vertical upstands and joints.



NEW PRODUCT

W-S Self-adhesive

A Water-Stop waterproof membrane
adhesive in patch and strip format.

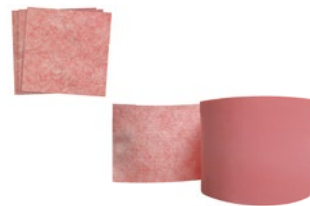

Safetub

Adaptable reinforcement for pipes, mixer
valves, roof vent stacks, etc.

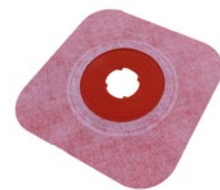

Ref.	Description	Measure	Format
IG61000	W-S Band 14	14 cm x 20 m	Roll
IG62000	W-S Band 34	34 cm x 20 m	Roll
IGU6032	W-S PatchSelf-adhesive	10 x 10 cm	Patch
IGU6031	W-S BandSelf-adhesive	12,5 cm x 20 m	Roll
IG60020	Safetub	Ø 32-50	Bag 5 units
IG60021	Safetub	Ø 63-75	Bag 5 units
IG60022	Safetub	Ø 90-128	Bag 5 units

100% Tailored shower systems

Every bathroom space is different, and that is why GURU shower systems are designed to fully adapt to the needs of each project. Their modular design and the variety of available configurations make it possible to create customized solutions, both in dimensions and finishes.

Technical precision, material quality and attention to detail combine to offer systems that integrate naturally into any bathroom style, providing functionality, aesthetics and long-term durability.



Kit Abierto

Tryphon Base Kit + Open Channel and Grate Kit

Our open kit is a complete solution made up of two packages:

Package 1 Tryphon Base Kit

This package forms the heart of the drainage system. It includes the Tryphon drain together with the Water-Stop waterproof membrane and its installation accessories.

Package 2 Channel + Grate

Consists of the channel + grate assembly, with options to choose from the various sizes and finishes of our Evolux and Revolux ranges.



Package 1 Tryphon Base Kit

The Tryphon Base Kit package includes a drain to be selected (Tryphon, Tryphon Reduced or Tryphon Vertical), according to the project requirements; the Water-Stop waterproof membrane with heat-sealed adapter, available in three sizes to be selected according to the area to be waterproofed; and the accessories required for a safe and efficient installation.

Ref.	Description
IC30009	Tryphon Base Kit - 3 m ²
IC30010	Tryphon Base Kit - 4 m ²
IC30011	Tryphon Base Kit - 5 m ²
IC30009R	Tryphon Base Kit - Reduced 3 m ²
IC30010R	Tryphon Base Kit - Reduced 4 m ²
IC30011R	Tryphon Base Kit - Reduced 5 m ²
IC30009V	Tryphon Base Kit - Vertical 3 m ²
IC30010V	Tryphon Base Kit - Vertical 4 m ²
IC30011V	Tryphon Base Kit - Vertical 5 m ²

System components



1. Drain to be selected (Tryphon, Tryphon Reduced or Tryphon Vertical) / 2. Interchangeable trap (water trap and dry trap) / 3. Hair strainer
4. Mortar levelling cap / 5. Water-Stop membrane with heat-sealed adapter (size to be selected) / 6. W-S Din x2 / 7. W-S Tub x2 /
8. Flexible Pushfit sleeve / 9. Tryphon Base Kit box







Package 2 Channel + Grate

The second package in the system, Channel + Grate, completes the base kit and defines its final finish. This assembly allows the choice between our two grate families: Evolux and Revolux, available in different sizes and finishes to suit the aesthetic and technical requirements of each project.





















On the one hand, Evolux channels and grates offer a robust and functional design with a wide variety of models to choose from. On the other hand, Revolux grates stand out for their cut-to-size system, which allows the length to be adjusted directly on site, providing a more versatile and adaptable installation.

Evolux Channel + Grate

Finish	Ref.	Model	Measure
●	RT41000	Lisa	60 cm
●	RT41001	Lisa	70 cm
●	RT41002	Lisa	80 cm
●	RT41003	Lisa	90 cm
●	RT41004	Lisa	100 cm
●	RT41005	Lisa	120 cm
●	RT41150	Lisa	150 cm
●	RT41180	Lisa	180 cm
●	RT42000	Plus	60 cm
●	RT42001	Plus	70 cm
●	RT42002	Plus	80 cm
●	RT42003	Plus	90 cm
●	RT42004	Plus	100 cm
●	RT42005	Plus	120 cm
●	RT42150	Plus	150 cm
●	RT42180	Plus	180 cm
-	RT45000	Integra	60 cm
-	RT45001	Integra	70 cm
-	RT45002	Integra	80 cm
-	RT45003	Integra	90 cm
-	RT45004	Integra	100 cm
-	RT45005	Integra	120 cm
-	RT45150	Integra	150 cm
-	RT45180	Integra	180 cm
●	RT51000	Lisa Dark	60 cm
●	RT51001	Lisa Dark	70 cm
●	RT51002	Lisa Dark	80 cm
●	RT51003	Lisa Dark	90 cm

	RT47000	Microcement	60 cm
	RT47001	Microcement	70 cm
	RT47002	Microcement	80 cm
	RT47003	Microcement	90 cm
	RT47004	Microcement	100 cm
	Rt47005	Microcement	120 cm

Revolux Grate

Finish	Ref.	Model	Measure
	RT23004	Curve Chrome	100 cm
	RT63004	Curve Gold	100 cm
	RT83004	Curve Rose	100 cm
	RT53004	Curve Black	100 cm
	RT93004	Curve Nickel	100 cm
	RT23200	Curve Chrome	200 cm
	RT63200	Curve Gold	200 cm
	RT83200	Curve Rose	200 cm
	RT53200	Curve Black	200 cm
	RT93200	Curve Nickel	200 cm
	RT24004	Cavity Chrome	100 cm
	RT64004	Cavity Gold	100 cm
	RT84004	Cavity Rose	100 cm
	RT54004	Cavity Black	100 cm
	RT94004	Cavity Nickel	100 cm
	RT24200	Cavity Chrome	200 cm
	RT64200	Cavity Gold	200 cm
	RT84200	Cavity Rose	200 cm
	RT54200	Cavity Black	200 cm
	RT94200	Cavity Nickel	200 cm

System components

Evolux



1. Evolux grate and channel (model and size to be selected) / 2. Hair strainer / 3. Hook for lifting grates

Revolux



1. Revolux grate (model and size to be selected) / 2. Hair strainer / 3. Trim / 4. End caps

Kit Abierto

Ruber Base Kit + Open Channel and Grate Kit

Our open kit is a complete solution made up of two packages:

Package 1 Ruber Base Kit

This package forms the heart of the system and includes the Ruber drain, the Water-Stop waterproof membrane and its installation accessories.

Package 2 Channel + Grate

The second package defines the finish of the installation, making it possible to choose between the different Evolux and Revolux channel and grate options, available in a wide variety of sizes and finishes.

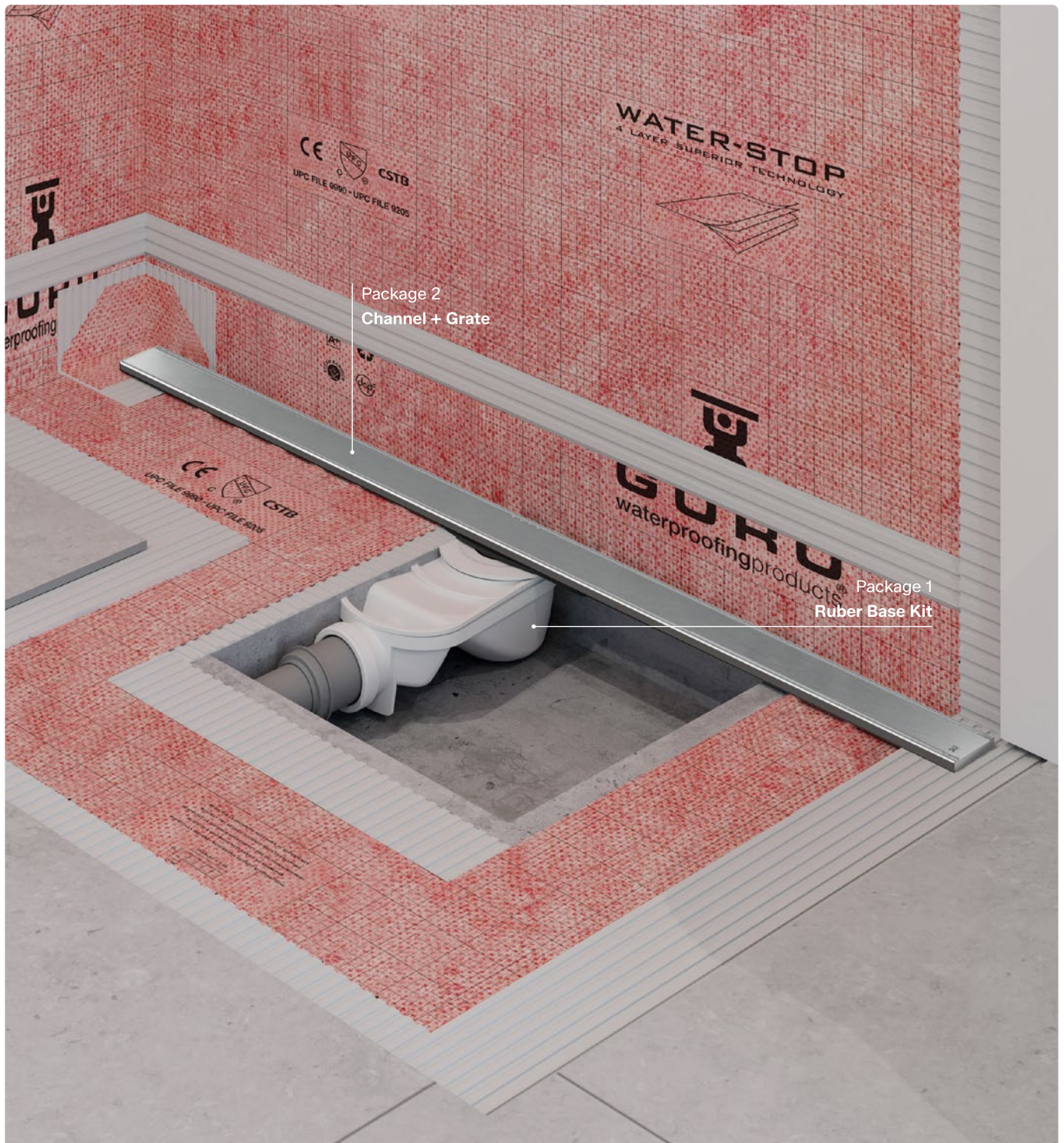

Package 1 Ruber Base Kit

The Ruber Base Kit package includes a drain to be selected (Ruber H50 or Ruber H28), according to the installation height required; the Water-Stop waterproof membrane with heat-sealed adapter, available in three sizes to be selected according to the area to be waterproofed; and the accessories required for a safe and efficient installation.

Ref.	Description
IC30003	Ruber Base Kit - 3 m ²
IC30004	Ruber Base Kit - 4 m ²
IC30012	Ruber Base Kit - 5 m ²
IC30003R	Ruber Base Kit - Reduced 3 m ²
IC30004R	Ruber Base Kit - Reduced 4 m ²
IC30012R	Ruber Base Kit - Reduced 5 m ²

System components



1. Drain to be selected (Ruber H50 or Ruber H28) / 2. Ruber collar / 3. Mortar levelling cap / 4. Ø50/40 reducer (only with Ruber H50) / 5. Water-Stop membrane with heat-sealed adapter (size to be selected) / 6. W-S Din x2 / 7. W-S Tub x2 / 8. Ruber Base Kit box

Package 2 Channel + Grate

The second package completes the base kit and defines its final finish. This assembly allows you to choose from different sizes and finishes across our two grate families: Evolux and Revolux.

Evolux Channel + Grate

Finish	Ref.	Model	Measure
●	ID30100	Lisa	11,6 × 11,6 cm
●	ID30200	Lisa	15 × 30 cm
●	ID30300	Lisa	60 cm
●	ID30400	Lisa	70 cm
●	ID30500	Lisa	80 cm
●	ID30600	Lisa	90 cm
●	ID30700	Lisa	100 cm
●	ID30800	Lisa	120 cm
●	ID31150	Lisa	150 cm
●	ID31180	Lisa	180 cm
●	ID30101	Plus	11,6 × 11,6 cm
●	ID30201	Plus	15 × 30 cm
●	ID30301	Plus	60 cm
●	ID30401	Plus	70 cm
●	ID30501	Plus	80 cm
●	ID30601	Plus	90 cm
●	ID30701	Plus	100 cm
●	ID30801	Plus	120 cm
●	ID32150	Plus	150 cm
●	ID32180	Plus	180 cm
-	ID30104	Integra	11,6 × 11,6 cm
-	ID30204	Integra	15 × 30 cm
-	ID30304	Integra	60 cm
-	ID30404	Integra	70 cm
-	ID30504	Integra	80 cm
-	ID30604	Integra	90 cm
-	ID30704	Integra	100 cm
-	ID30804	Integra	120 cm
○	ID40209	Cristal	15 × 30 cm
○	ID40409	Cristal	70 cm
○	ID40509	Cristal	80 cm
○	ID40609	Cristal	90 cm
●	ID50100	Lisa Dark	11,6 × 11,6 cm
●	ID50200	Lisa Dark	15 × 30 cm
●	ID50300	Lisa Dark	60 cm

●	ID50400	Lisa Dark	70 cm
●	ID50500	Lisa Dark	80 cm
●	ID50600	Lisa Dark	90 cm
●	ID37100	Microcement	11,6 × 11,6 cm
●	ID37200	Microcement	15 × 30 cm
●	ID37300	Microcement	60 cm
●	ID37400	Microcement	70 cm
●	ID37500	Microcement	80 cm
●	ID37600	Microcement	90 cm
●	ID37700	Microcement	100 cm
●	ID37800	Microcement	120 cm

Revolux Grate

Finish	Ref.	Model	Measure
●	ID23004	Curve Chrome	100 cm
●	ID63004	Curve Gold	100 cm
●	ID83004	Curve Rose	100 cm
●	ID53004	Curve Black	100 cm
●	ID93004	Curve Nickel	100 cm
●	ID23200	Curve Chrome	200 cm
●	ID63200	Curve Gold	200 cm
●	ID83200	Curve Rose	200 cm
●	ID53200	Curve Black	200 cm
●	ID93200	Curve Nickel	200 cm
●	ID24004	Cavity Chrome	100 cm
●	ID64004	Cavity Gold	100 cm
●	ID84004	Cavity Rose	100 cm
●	ID54004	Cavity Black	100 cm
●	ID94004	Cavity Nickel	100 cm
●	ID24200	Cavity Chrome	200 cm
●	ID64200	Cavity Gold	200 cm
●	ID84200	Cavity Rose	200 cm
●	ID54200	Cavity Black	200 cm
●	ID94200	Cavity Nickel	200 cm

System components

Evolux



1. Evolux grate and channel (model and size to be selected) / 2. Hair strainer / 3. Hook for lifting grates

Revolux



1. Revolux grate (model and size to be selected) / 2. Hair strainer / 3. Trim / 4. End caps



Modular Systems

01 Corporate Brochure

02 Technical Membranes

03 Drainage Systems

04 Modular Systems

At GURU, we transform complex processes into agile, precise solutions, where every component fits together with technical rigour to maximise productivity.



Product Index

In our modular systems, innovation and design come together, so every detail is conceived to ensure **fast and efficient installation**, together with fully customised finishes.

The installation of dry construction systems ensures a fast, clean and controlled process, reducing on-site errors and optimising time and costs.

Modular systems

Superkit P 152-155

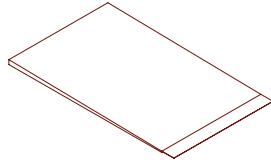

W-S Board P 156-159

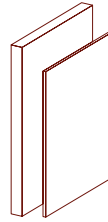

W-S Basink P 160-163

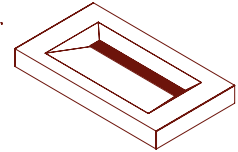

W-S Sink P 164-165

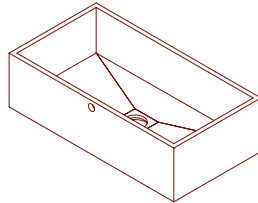

W-S Niche P 166-167

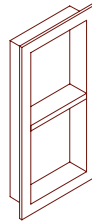

Shelf Niche P 168-169

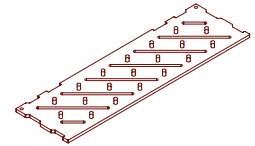

W-S Niche Cut-to-Size P 170-171

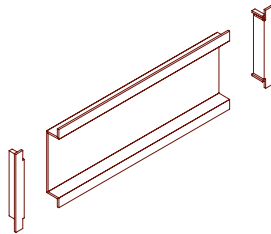

W-S Bench P 172-173

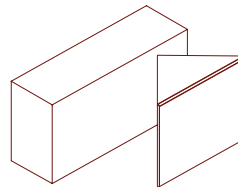

W-S Planter P 174-175

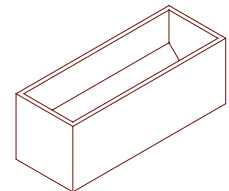

Installation accessories

Screws and washers P 158

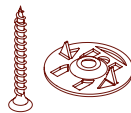

W-S Self-Adhesive P 158

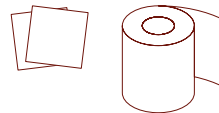

Profiles P 159

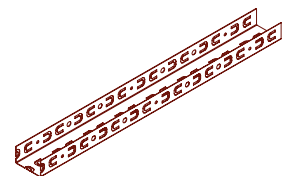





Superkit Complete system with prefabricated falls



Product				Logistics
Ref.	Description	Shower tray size	Grate size	Units/Pallet
IS45001	Superkit - Evolux Integra	90 x 150 cm	70 cm	13
IS45002	Superkit - Evolux Integra	90 x 150 cm	80 cm	13
IS45003	Superkit - Evolux Integra	90 x 150 cm	90 cm	13
IS00001	Superkit - Revolux Cavity Chrome	90 x 150 cm	100 cm	13

Superkit is a **shower system** that includes the components required to build tiled shower bases. Its main element is a shower tray with a factory-made 2% fall that is also easy to cut, allowing it to be adapted to any space. Together with the included grate and channel, this guarantees a fully customised finish, since both the grate and the tray are fully easy to cut. In addition, its intuitive design enables quick and precise installation, ensuring efficient fitting in record time and complete waterproofing thanks to our Water-Stop membrane, also included in the kit.

Features	Easy installation	Technical data	
	Cut-to-size format: easy to trim with a utility knife		Preformed shower tray with 2% falls
	Latest-generation drainage system		High drainage capacity: up to 32 L/min
			Highly resistant high-density polyurethane

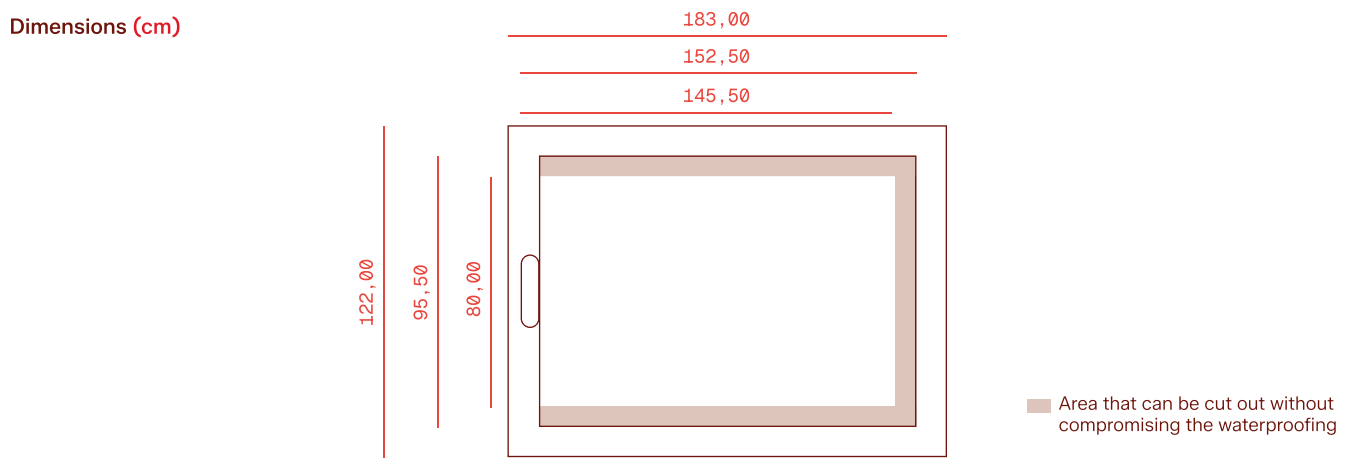

System contents

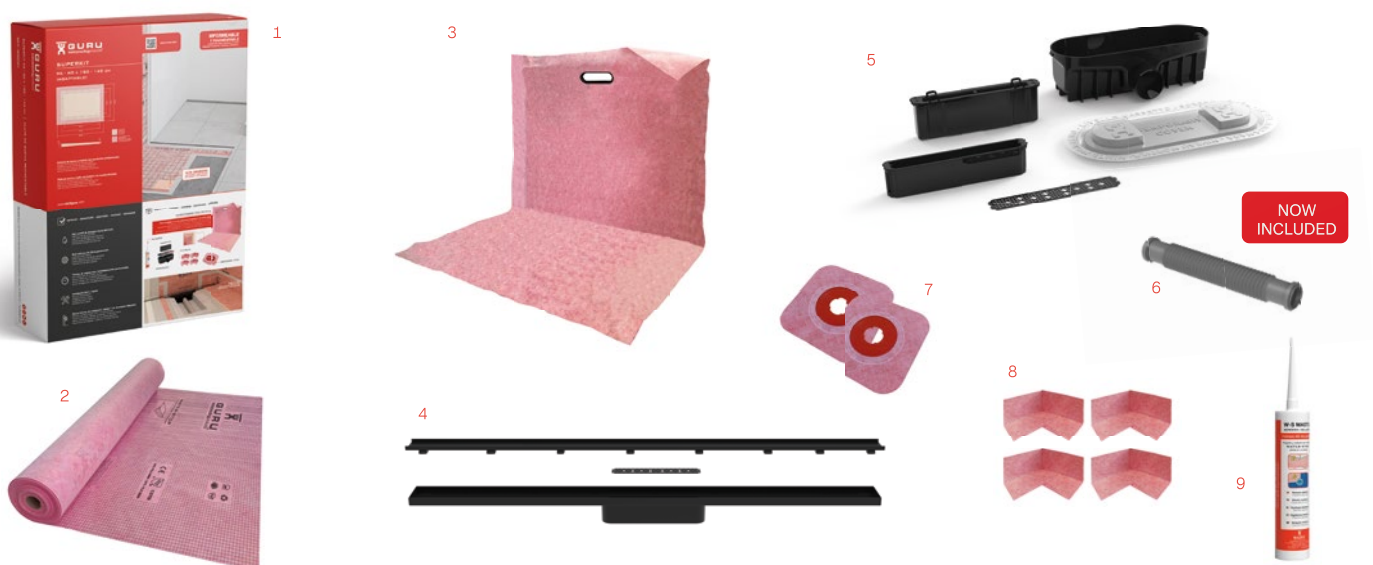

1. Superkit box / 2. Water-Stop membrane 1x10m / 3. Cut-to-size W-S Ready Shower shower tray / 4. Evolux Integra grate and channel (size to be selected) or Revolux Cavity Chrome and Tryphon hair strainer / 5. Tryphon drain with dry or water trap, installation protection cover and hair strainer / 6. Pushfit flexible sleeve / 7. Safetub Ø32-50 cm x2 / 8. W-S Din x4 / 9. W-S Mastic 290 ml

Complete your kit

Step 1 Choose the finish

Revolux Tryphon Kit



Finish	Ref.	Model	Size
	IT23004	Curve Chrome	100 cm
	IT63004	Curve Gold	100 cm
	IT83004	Curve Rose	100 cm
	IT53004	Curve Black	100 cm
	IT93004	Curve Nickel	100 cm
	IT24004	Cavity Chrome	100 cm
	IT64004	Cavity Gold	100 cm
	IT84004	Cavity Rose	100 cm
	IT54004	Cavity Black	100 cm
	IT94004	Cavity Nickel	100 cm

For more options, see Drainage Systems: (page 92) ►

Revolux Ruber Kit



Finish	Ref.	Model	Size
	IE23004	Curve Chrome	100 cm
	IE63004	Curve Gold	100 cm
	IE83004	Curve Rose	100 cm
	IE53004	Curve Black	100 cm
	IE93004	Curve Nickel	100 cm
	IE24004	Cavity Chrome	100 cm
	IE64004	Cavity Gold	100 cm
	IE84004	Cavity Rose	100 cm
	IE54004	Cavity Black	100 cm
	IE94004	Cavity Nickel	100 cm

For more options, see Drainage Systems: (page 94) ►

Evolux Tryphon Kit



Finish	Ref.	Model	Size
	IT41002	Lisa	80 cm
	IT41003	Lisa	90 cm
	IT41004	Lisa	100 cm
	IT41005	Lisa	120 cm
-	IT45002	Integra	80 cm
-	IT45003	Integra	90 cm
-	IT45004	Integra	100 cm
-	IT45005	Integra	120 cm

For more options, see Drainage Systems: (pages 98-105) ►

Evolux Ruber Kit



Finish	Ref.	Model	Size
	IE41002	Lisa	80 cm
	IE41003	Lisa	90 cm
	IE41004	Lisa	100 cm
	IE41005	Lisa	120 cm
-	IE45002	Integra	80 cm
-	IE45003	Integra	90 cm
-	IE45004	Integra	100 cm
-	IE45005	Integra	120 cm

For more options, see Drainage Systems: (pages 106-113) ►

Complementary accessories



Water-Stop



Vertical Tryphon drain body



W-S Mastic

Ref.	Description	Size	Finish
IF51000	Water-Stop roll	1 x 5 m	-
IF51013	Water-Stop roll	1 x 10 m	-
IF52000	Water-Stop roll	1 x 30 m	-
IF54000	Water-Stop roll	1,5 x 20 m	-
IG64000	W-S Mastic	290 m	-
IG60032	Vertical Tryphon drain body	-	-

Step 2 Forget about creating the falls

W-S Ready Shower

W-S Ready Shower is a prefabricated shower tray with integrated falls, ready to tile and waterproofed. It includes an extended front membrane flap to ensure a secure and watertight connection to the drainage system.

With an integrated 2% slope



Features

Prefabricated	Easy to cut
Integrated falls 2%	Waterproofed
Ready to tile	Fast to install

Product

Ref.	Description	Size with Tryphon / Ruber	Pcs / Big Box
IM92000	Shower tray	80 × 120 cm	24
IM92010	Shower tray	90 × 120 cm	24
IM92011	Shower tray	90 × 150 cm	24
IM92020	Shower tray	100 × 150 cm	14
IM92021	Shower tray	100 × 180 cm	14
IM92030	Shower tray	120 × 120 cm	36
IM92031	Shower tray	120 × 180 cm	14

Logistics

*Available only in Big Box format. Quantity determined according to size.

Dimensions (cm)

With Tryphon adapter

120,00 - 150,00 - 180,00

109,00 - 139,00 - 169,00

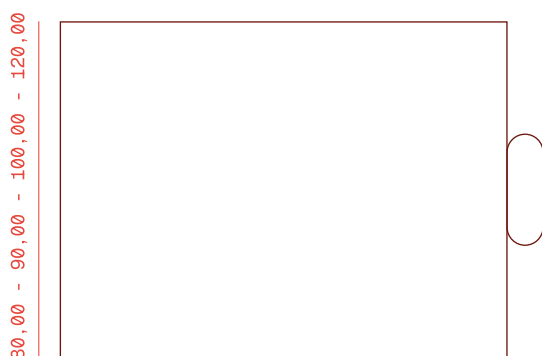

With an integrated 2% slope

With Ruber adapter

120,00 - 150,00 - 180,00

109,00 - 139,00 - 169,00

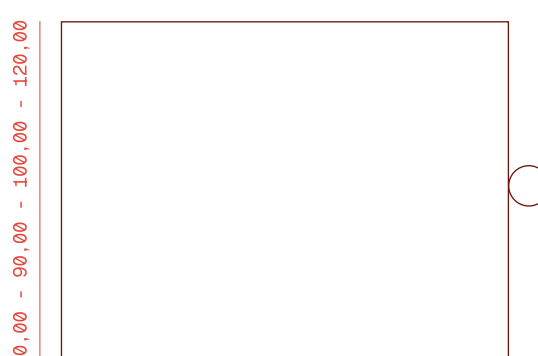

With an integrated 2% slope

Complementary accessories

Ref.	Description	Size	Finish
IJ80016	G-Pro Level - Left	180 cm	Inox
IJ80026	G-Pro Level - Left	180 cm	White
IJ80028	G-Pro Level - Left	180 cm	Dark
IJ80030	G-Pro Level - Right	180 cm	Inox
IJ80040	G-Pro Level - Right	180 cm	White
IJ80042	G-Pro Level - Right	180 cm	Dark



G-Pro Level

W-S Board Dry construction panel



W-S Board is a waterproof dry construction panel that is versatile, lightweight and easy to cut, helping to speed up the construction process. It significantly reduces installation time and costs. In addition, thanks to the variety of available thicknesses, it adapts to multiple residential and industrial applications and projects.

Its waterproof core provides high resistance to moisture and protection against leaks and condensation. At the same time, its flat, uniform surface ensures consistent finishes and excellent adhesion for ceramic tiles.

Features

Available sizes(mm): 2600 × 625 mm / 2600 × 1200 mm
 Available thicknesses (mm): 10 - 12,5 - 50
 Easy to cut
 Waterproof
 Flat and uniform panel
 Lightweight
 Reduces installation time

Technical data

Compressive strength: 500 KPA - 50 PSI
 < 0.3 perms - ideal for steam showers
 Fire resistance
 Thermal conductivity lambda

Product

Ref. Description Size

IM93018 W-S Board 2600 × 625 × 10 mm
 IM93019 W-S Board 2600 × 625 × 12,5 mm
 IM93017 W-S Board 2600 × 625 × 50 mm
 IM93024 W-S Board 2600 × 1200 × 12,5 mm

Logistics

Weight/panel Units/Pallet

1,8 kg 100
 1,9 kg 80
 4 kg 21
 3,65 kg 80

NEW

For logistics reasons, the minimum order quantity for W-S Board is one full pallet.



W-S Board Pre-Cut packs

Product

Ref. Description Size

IB93024 Pack 5 pcs: W-S Board Pre-Cut* 2600 × 1200 × 12,5 mm
 IBU9312 Pack 7 pcs: W-S Board Pre-Cut* 1524 × 914 × 12,5 mm

NEW

Installation accessories

Screws and metal washers



Product			Logistics
Ref.	Description	Size	Units/Pallet
IG60026	200 Screws	-	-
IG60027	200 Metal washers	-	-
IG60028	KIT 100 Screws and 100 washers	-	-

W-S Self-Adhesive

Self-adhesive Water-Stop membrane accessories designed for wall-only applications, offering an easier and faster alternative to conventional solutions. Available in two formats: 10 × 10 cm patches and a cut-to-size strip that can be adjusted to the needs of each installation

W-S Self-Adhesive Patch

Complementary product:
Metal washer



W-S Self-Adhesive Band

Capable of sealing two flat waterproofed surfaces.



Product		
Ref.	Description	Size
IGU6031	W-S Self-Adhesive Band	12,5 cm x 20 m
IGU6032	W-S Self-Adhesive Patch	10 cm x 10 cm

Profiles

U-shaped galvanised steel profiles.

Suitable for the fixing and installation of 5 cm-thick W-S Board panels

Features	"U" shape
	Manufactured from galvanised steel

Technical data	Length (mm): 2600
	Width (mm): 50
	Height (mm): 30

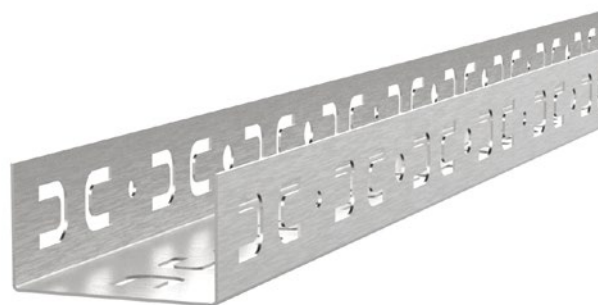

Dimensions

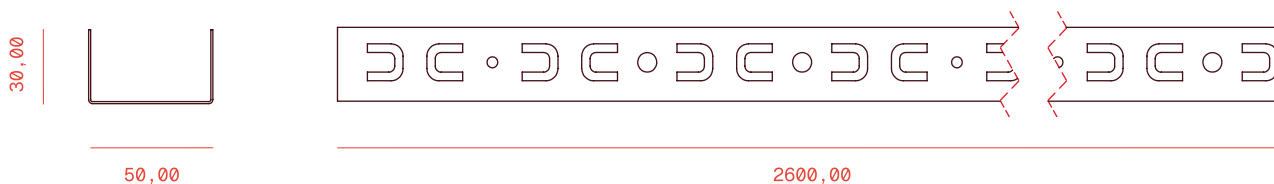

Product

Ref.	Description	Size
IZ60000	Perfil U Board 50 mm	2600 mm
IB50003	Pack 6 pcs: Perfil U Board 50 mm	2600 mm

Fixing W-S Board to the installation profile

Complete the installation with W-S Mastic.



1. Mounting profile / 2. W-S Board (2600 × 625 × 50 mm) / 3. W-S Mastic

W-S Basink Prefabricated washbasin



W-S Basink is a prefabricated, easy to cut and fully waterproofed washbasin, ideal for different installation types: wall-hung, between three walls, corner installation or supported installation.

It includes a 10 cm easy to cut area that allows the tap to be installed either on the basin itself or on the wall, adapting to the required configuration.

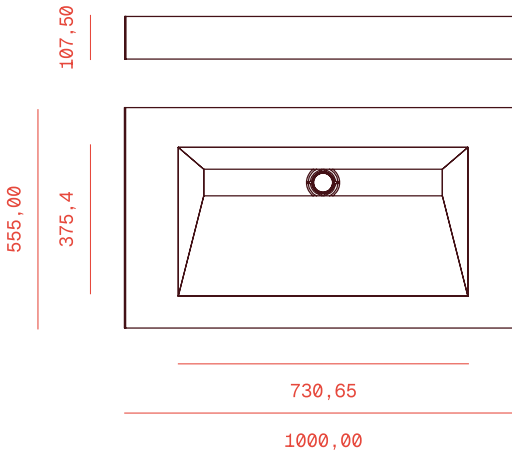
Features	<ul style="list-style-type: none"> Prefabricated and waterproofed Easy to cut Tileable Adaptable to different installation types Two tap options: wall-mounted or deck-mounted Levelling system to facilitate installation 	Dimensions (mm) 
Technical data	<ul style="list-style-type: none"> Supports a load of 180 kg Vertical outlet Ø50 Vertical adjustment 	

Installation types

Installation Wall-hung

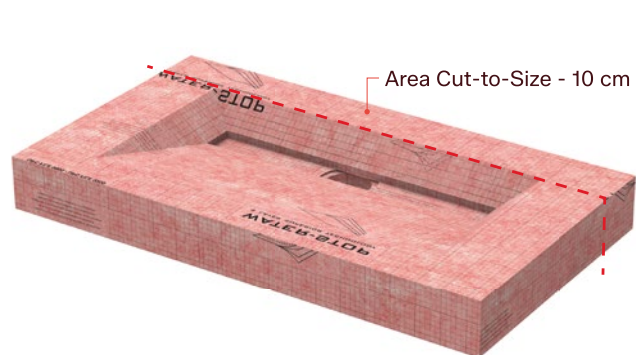

Installation Supported



W-S Board
Complementary accessory (IM93017)
* See more on p.156 ►

Product			Logistics
Ref.	Description	Size	Units/Pallet
IM04000	W-S Basink Integra / Tileable	1000 × 555 × 107,5 mm	5
IM04002	W-S Basink Customisable *	1000 × 555 × 107,5	5

*Select the channel + grate finish separately.

System contents



1. Prefabricated W-S Basink washbasin / 2. Evolux Integra channel and grate included only in Ref. IM04000 / 3. Ruber adapter with vertical outlet / 4. W-S Mastic 290 ml / 5. Adjustable load-bearing supports / 6. Ø50-40 reducer / 7. M6 grub screws (x4) / 8. M6 pan-head screws (x4) / 9. Grate removal tool / 10. QR code with cutting templates / 11. W-S Basink box

Complementary accessories

Other finishes available through separate purchase.

Evolux Channel + grate



Compatible with 60 cm dimensions

Revolux Grate



Compatible with cuttable 100 cm Revolux

Evolux Channel + grate

Finish	Ref.	Model	Size
	ID30300	Lisa	60 cm
	ID30301	Plus	60 cm
	ID50300	Lisa Dark	60 cm
	ID37300	Microcement	60 cm

Revolux Grate

Finish	Ref.	Model	Size
	ID23004	Curve Chrome	100 cm
	ID63004	Curve Gold	100 cm
	ID83004	Curve Rose	100 cm
	ID53004	Curve Black	100 cm
	ID93004	Curve Nickel	100 cm
	ID24004	Cavity Chrome	100 cm
	ID64004	Cavity Gold	100 cm
	ID84004	Cavity Rose	100 cm
	ID54004	Cavity Black	100 cm
	ID94004	Cavity Nickel	100 cm

Support W-S Basink

Ref.	Ref.
IZ60020	Adjustable load-bearing support



Efficient installation. Exclusive finishes.

GURU modular systems enable efficient and versatile installation, designed to **simplify every project.**

W-S Sink

Prefabricated kitchen sink



Product

Ref. Description

Size

IM04001

W-S Sink

850 x 450 x 240 mm

Logistics

Units/Pallet

12

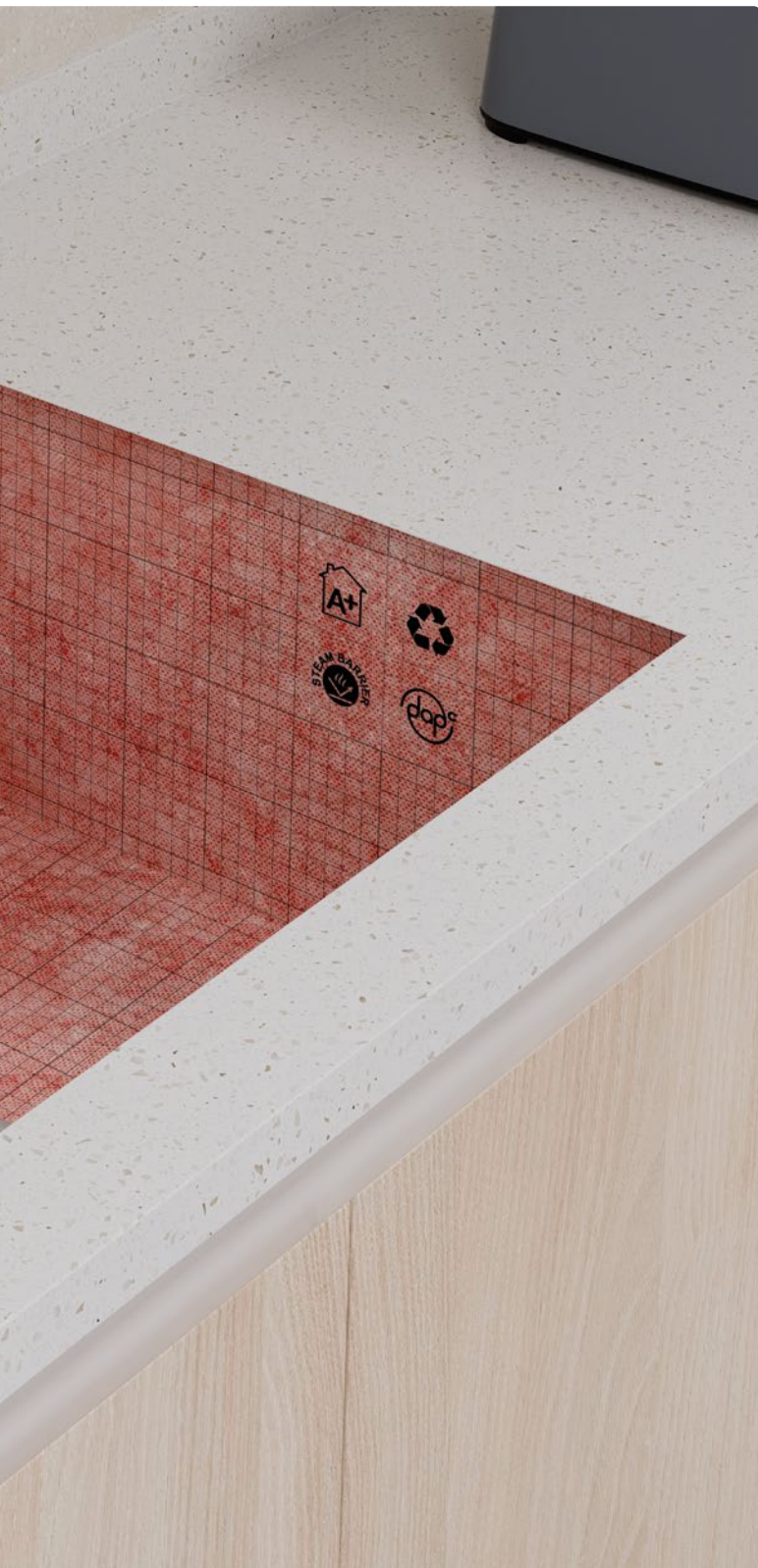

W-S Sink is a prefabricated and **waterproofed** kitchen sink with a Pre-sloped base and **tileable** interior, suitable for ceramic tile or microcement finishes.

Its spacious design provides a large washing area within the worktop, offering a functional and aesthetic solution for any space.



Features	<ul style="list-style-type: none"> Prefabricated and waterproofed Ready to tile Adaptable to different installation types
-----------------	--

Technical data	<ul style="list-style-type: none"> External dimensions 850 × 450 × 240 mm Internal falls: 1,5%
-----------------------	--

Dimensions (mm)

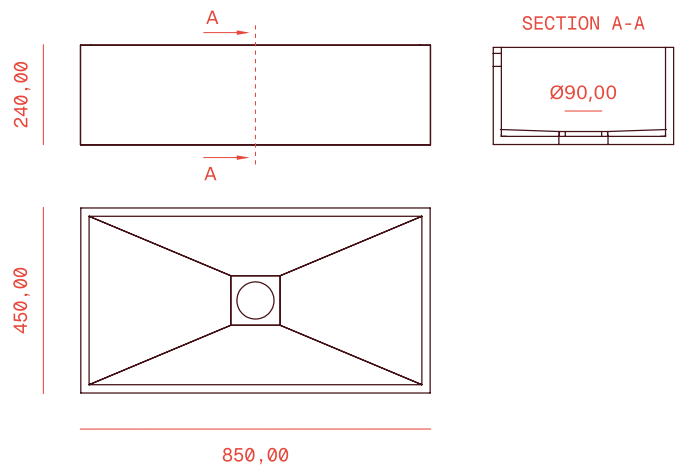

W-S Niche Prefabricated shower niche



Product				Logistics
Ref.	Description	Internal dimensions	External dimensions	Units/Pallet
IMU5000	W-S Niche	30,5 × 30,5 × 8,6 cm	40,6 × 40,6 × 9,85 cm	79
IMU5001	W-S Niche	50,8 × 30,5 × 8,6 cm	60,9 × 40,6 × 9,85 cm	69
IMU5002	W-S Niche	60,9 × 30,5 × 8,6 cm	71,1 × 40,6 × 9,85 cm	59
IMU5003	W-S Niche	71,1 × 30,5 × 8,6 cm	81,3 × 40,6 × 9,85 cm	44

NEW

W-S Niche is a prefabricated, **waterproof and tileable** shower niche designed with a 1.5% **Pre-sloped base** to ensure efficient drainage. Its internal dimensions are aligned with standard ceramic tile formats, avoiding unsightly cuts and reducing finishing time. In addition, it includes a 25 mm internal shelf, adjustable in height during installation, to optimise usable space.



Features

- Rigid XPS foam core
- Prefabricated and waterproofed
- Fully tileable
- Horizontal or vertical installation
- Adjustable shelf

Technical data

- Internal shelf 25 mm *
- Watertight structure bonded with polyurethane
- Four sizes available
- Pre-sloped base:: 1,5%

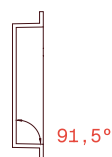

Dimensions (mm)

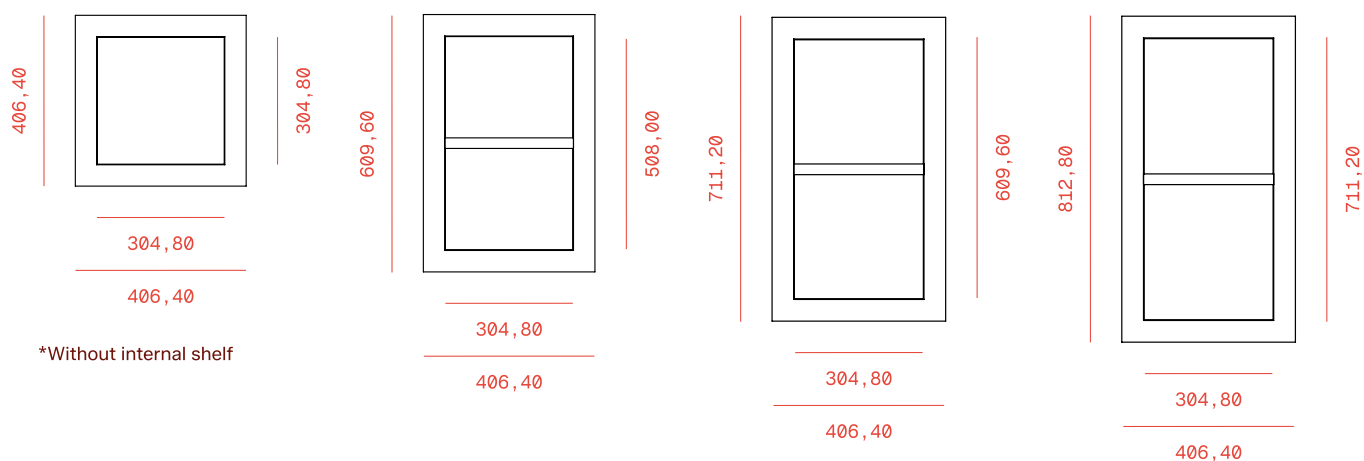

System contents

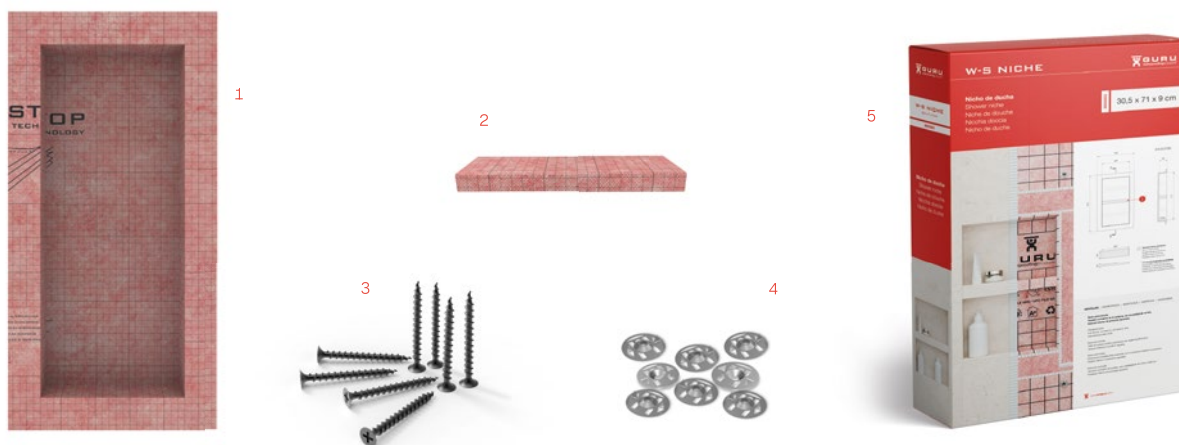

1. Prefabricated W-S Niche / 2. Divider shelf* / 3. Screws (x8) / 4. Metal washers (x8) / 5. W-S Niche Box

*Not included in W-S Niche 30

Shelf Niche

Shelf
for niche



Description

Ref.	Description
IMU0411	Shelf Niche Line Inox Brushed
IMU0401	Shelf Niche Cross Inox Brushed
IMU0412	Shelf Niche Line Dark
IMU0402	Shelf Niche Cross Dark
IMU0414	Shelf Niche Line Nickel
IMU0404	Shelf Niche Cross Nickel
IMU0413	Shelf Niche Line Gold
IMU0403	Shelf Niche Cross Gold
IMU0400	Shelf Niche Glass

NEW

Shelf Niche is a niche shelf that requires no drilling or perforation for installation, preserving the waterproof integrity of both the niche and the walls, as it is fixed directly into the grout joint between the tiles.

Shelf Niche Inox

Features

Easy installation
 Minimum joint width of 4 mm between tiles for installation



Technical data

Thickness: 4 mm
 Dimensions: 300 x 88 mm
 Manufactured from stainless steel AISI 316 - Marine grade
 Two models: CROSS and LINE
 Four finishes: INOX, DARK, GOLD and NICKEL

Dimensions (mm)

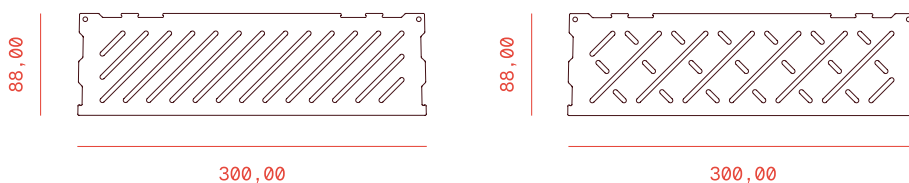

Models y Finishes

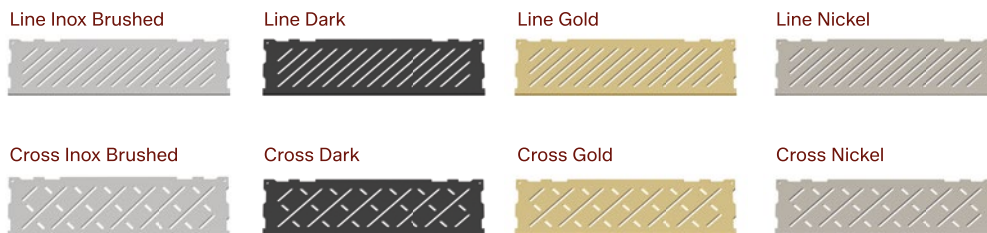

Shelf Niche Glass

Features

Easy installation
 Minimum joint width of 10 mm between tiles for installation

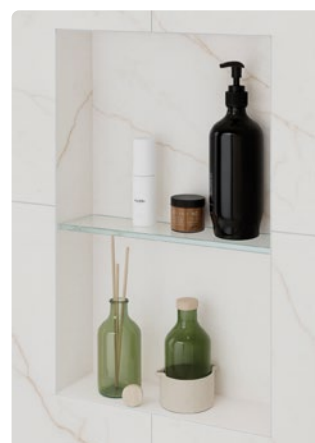

Technical data

Thickness: 10 mm
 Dimensions: 300 x 88 mm
 Low-iron tempered glass

Dimensions (mm)

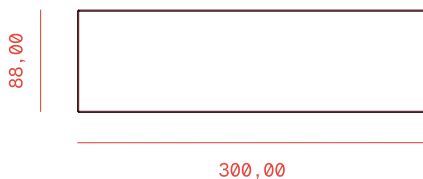

Model

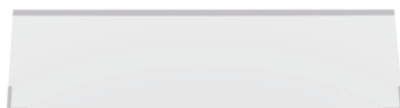

W-S Niche Cut-to-Size Niche

CUT-TO-SIZE



Cut-to-Size system

Adjust dimensions

Fold and assemble

Position and bond the end caps using sealing adhesive



Description

Logistics

Ref.

Description

Units/Pallet

IM50020

W-S Niche Cut-to-Size

40



Maintaining the **waterproofing** performance and durability of the W-S Niche system, the **cut-to-size** version allows the length to be adjusted, offering a solution adaptable to any space. Ideal for projects requiring customisation, it ensures **easy installation** and professional finishes without compromising quality.



Features

- Adaptable to different installation types
- Waterproof
- Tileable
- Easy to cut with a utility knife

Technical data

- Maximum length: 140 cm
- Internal height without finish: 40 cm
- Pre-sloped base: 1,5%
- Requires support structure



91,5°

Dimensions (mm)

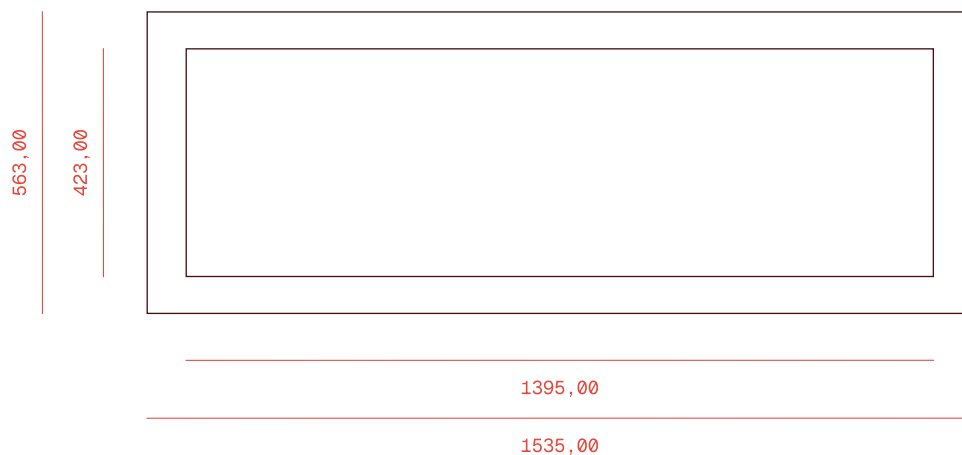

W-S Bench Tileable Shower seat



Installation accessories included in the system:

W-S Bench Triangular

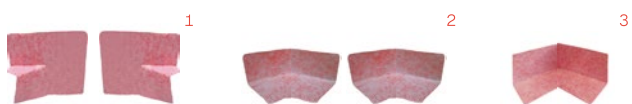

1. W-S Dex 135° (2 pcs) / 2. W-S Din 135° (2 pcs) / 3. W-S Din (1 pc)

NEW

NEW

W-S Bench Rectangular



1. W-S Din (2 pcs.) / 2. W-S Dex (2 pcs.)

Product

Ref.	Description	Model	Size
IMU4011	W-S Bench	Triangular	40,6 × 40,6 × 57,4 × 50,8h cm
IMU4010	W-S Bench	Triangular	60,9 × 60,9 × 86,36 × 50,8h cm
IMU4038	W-S Bench	Rectangular	91,44 × 29,21 × 50,70h cm
IMU4048	W-S Bench	Rectangular	121,92 × 40,64 × 50,70h cm

NEW

W-S Bench is a **waterproof and tileable** shower seat manufactured from our W-S Board dry construction panel. Its **top surface features** a 1.5% slope to facilitate water runoff and avoid water-tightness issues.

In addition, it offers great strength, having been tested to withstand **loads of up to 200 kg** without deformation or loss of height due to compression.

Features	<ul style="list-style-type: none"> Prefabricated and waterproofed Lightweight and easy to transport Ready to install Tileable High strength, +200 kg Vapour and heat barrier 	Technical data	Top surface slope: 1.5%
-----------------	--	-----------------------	-------------------------

Models

Triangular

Rectangular



Dimensions (mm)

W-S Bench Triangular

406 x 406 x 574,70 x 508h

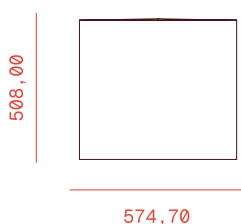

W-S Bench Triangular

609 x 609 x 863,60 x 508h

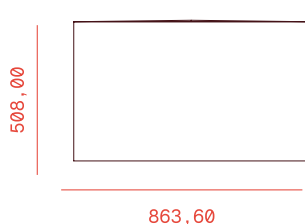

W-S Bench Rectangular

914,4 x 292,1 x 507

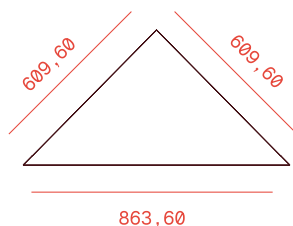
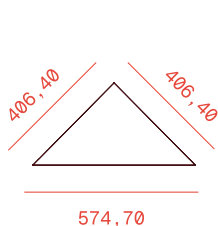
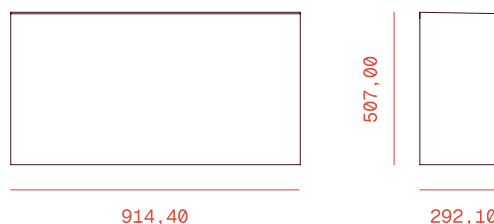

W-S Bench Rectangular

1219,2 x 406,4 x 507

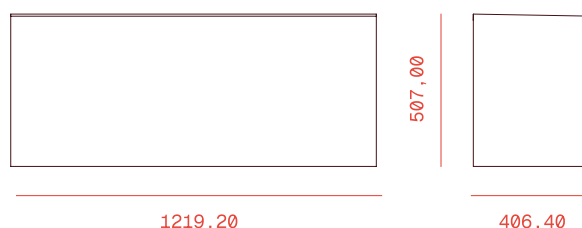

W-S Planter

Tileable
Planter



Product

Ref.	Description	Size
IM06000	W-S Planter	795 x 295 x 295 mm

NEW



W-S Planter is a modular **tileable** planter manufactured from W-S Board, designed to provide durability and resistance in exterior applications.

It includes a **Ø20 mm drainage outlet** to facilitate water evacuation.

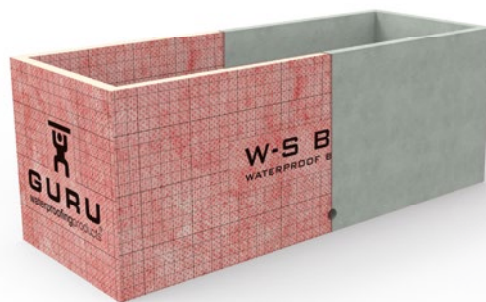

Features

- Prefabricated and waterproofed
- Drainage outlet Ø20 mm
- Lightweight
- Ready to install
- Tileable

Technical data

- Width (mm): 295
- Height (mm): 295
- Length (mm): 795
- Capacity (L): 50

Dimensions (mm)

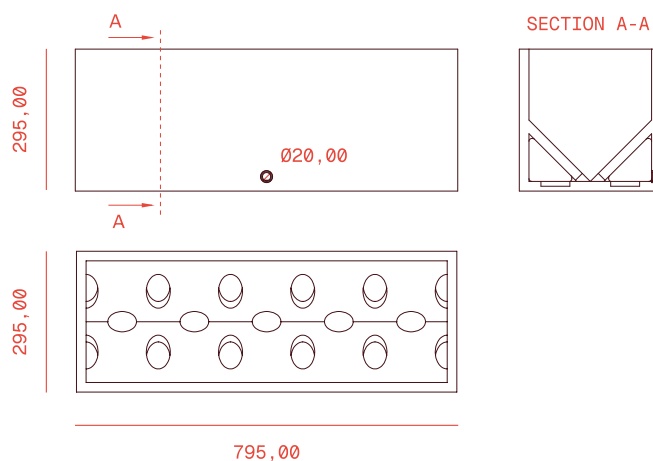





GURU Headquarters

C/ de l'Ordin, 10 Ontinyent, Valencia
T (+34) 96 291 45 11

info@estilguru.com

GURU Offices

C/ dels Telers, 22 Ontinyent, Valencia
T (+34) 96 291 45 11

info@estilguru.com

www.estilguru.com

The
waterproofing
experts

